

SELF-PRIMING ENGINE DRIVEN PUMP

22M - 13 HP

Suction: 3"

Discharge: 3"



SUCTION

3" NPT female, horizontal, bolt on flange.

DISCHARGE

3" NPT female, vertical.

BODY

Cast iron ASTM A-48 class 30.

INTERMEDIATE

Cast iron ASTM A-48 class 30.

IMPELLER

Design: 5 vanes, semi-open with a spherical solid handling of 3/4", statically balanced.

Material: cast iron ASTM A-48 class 30.

SHAFT SLEEVE

Steel.

CHECKVALVE

Valve: flap-neoprene.

Weight: steel.

O-RINGS

Buna-N.

SHIM SET

Stainless steel.

SEAL

Design: mechanical, water lubricated.

Material: ceramic stationary part, carbon ring seal and exclusion in the rotating part. Buna-N elastomer and stainless steel spring.

STRAINER

Steel.

ENGINES

Assembled to a gasoline engine, single-cylinder, 4-stroke OHV, air-cooled.

MOUNTING

- ▶ Base mounted
- ▶ On skid with iron or rubber wheels or pneumatic 5.6" x 15" tires.

ENGINE	MODEL	HP	STARTING
Honda	GX390	13	Electric

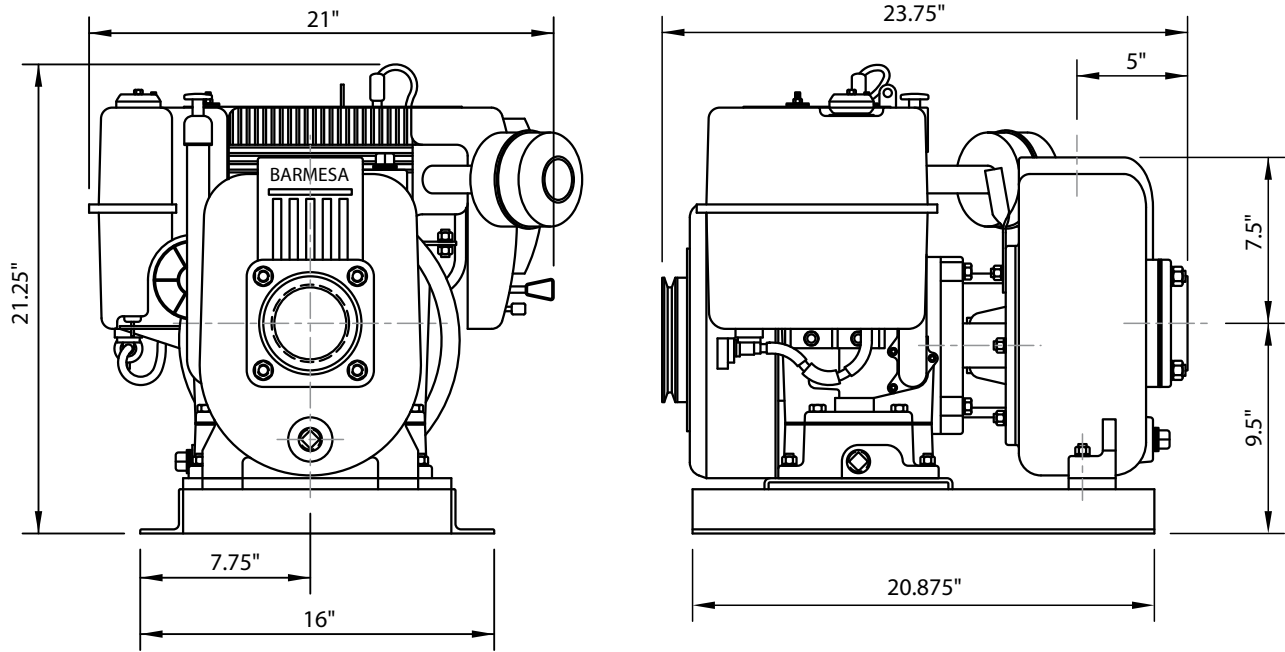

**PERFORMANCE CHART
A NORMAL SPEED REGIME**

MODEL & SIZE	TOTAL DYNAMIC HEAD W/ FRICTION (meters)	TOTAL PUMP HEIGHT OVER THE SEA LEVEL (meters)			
		3.1	4.6	6	7.6
		LITERS PER MINUTE			
22M 7.62 cm (3")	11.3	1,400	1,260	-	-
	15.5	1,350	1,190	977	850
	19.7	1,250	1,050	910	815
	23.5	1,000	890	840	735
	27.6	820	756	690	690
	31.3	620	620	620	620

IMPORTANT!

1. Never use this pump to handle explosive liquids.
2. This pump is not approved to be used in swimming pools, recreational installations or any application where human contact may be common.
3. Pump may be operated "dry" for extended periods without damage to motor and/or seals.