

SUBMERSIBLE SOLIDS HANDLING PUMP

Series: 4BWSE-DS
2 - 7.5 HP / 1750 RPM
Discharge: 4"
Spherical solids handling: 3"



DISCHARGE

4", 125lb, flange horizontal.

LIQUID TEMPERATURE

104 °F (40 °C) continuous, 140 °F (60 °C) intermittent operation.

VOLUTE

Cast iron ASTM A-48 class 30.

MOTOR HOUSING

Cast iron ASTM A-48 class 30.

SEAL PLATE

Cast iron ASTM A-48 class 30.

IMPELLER

Design: 2 vane, semi-open, with vanes on back side.

Material: cast iron ASTM A-48 class 30.

SHAFT

416 series stainless steel.

SQUARE RINGS

Buna-N.

PAINT

Air dry enamel, water based.

SEAL

Design: dual, mechanical, oil filled chamber.

Material: silicon carbide with Viton type 01 outer seal, carbon ceramic with Buna-N type 01 inner seal, with stainless steel hardware.

HARDWARE

300 series stainless steel.

CORD ENTRY

40 ft of cord, epoxy sealed housing with secondary pressure grommet for sealing and strain relief.

MOTOR

NEMA B, three phase, 230 & 460 volts, 60 Hz, 1750 RPM, oil filled, with class F insulation. Requires overload protection to be included in control panel.

OPTIONAL EQUIPMENT

Additional cord, tungsten carbide seal, slide rail coupling (SRC-4).

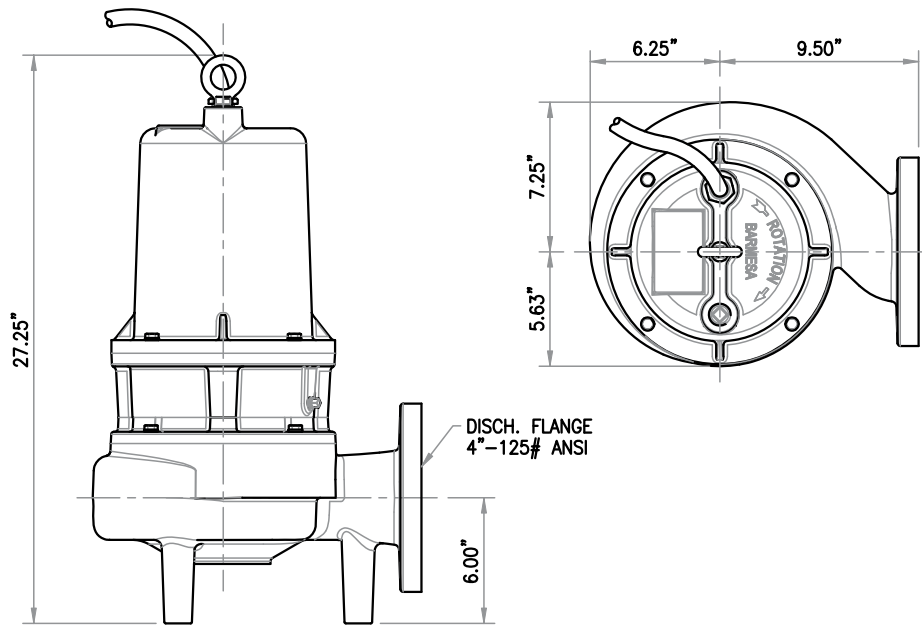

MODEL	PART No.	HP	VOLTS	PHASE	RPM (Nominal)	MAX AMPS	LOCKED ROTOR AMPS	NEMA CODE	CORD SIZE	CORD TYPE	WEIGHT (pounds)
4BWSE203DS	62170151	2	230	3	1750	11.6	40	F	14/4	STOW	200
4BWSE204DS	62170152	2	460	3	1750	5.8	20	F	14/4	STOW	200
4BWSE303DS	62170153	3	230	3	1750	14.4	49.5	H	14/4	STOW	205
4BWSE304DS	62170154	3	460	3	1750	7.2	24.8	H	14/4	STOW	205
4BWSE503DS	62170155	5	230	3	1750	19.8	63.6	E	14/4	STOW	210
4BWSE504DS	62170156	5	460	3	1750	9.9	31.8	E	14/4	STOW	210
4BWSE753DS	62170157	7.5	230	3	1750	23	105	G	10/4	STOW	225
4BWSE754DS	62170158	7.5	460	3	1750	11.5	52.5	G	10/4	STOW	225

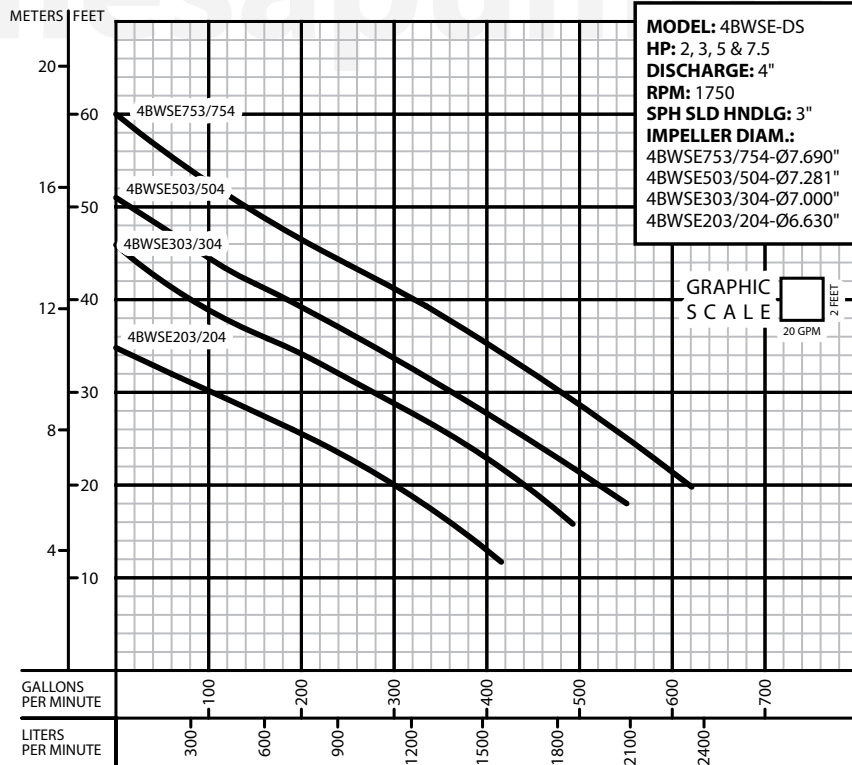

IMPORTANT!

1. Never use this pump to handle explosive liquids.
2. This pump is not approved to be used in swimming pools, recreational installations or any application where human contact may be common.
3. Pump may be operated "dry" for extended periods without damage to motor &/or seals.
4. Testing is performed with water specific gravity of 1.0 @ 68 °F (20 °C); other fluids may vary performance.