

SUBMERSIBLE SOLIDS HANDLING PUMP

Series: 6BSE-LDS
18-60 HP / 1750 RPM
Discharge: 6"
Spherical solids handling: 3"



DISCHARGE

6", 125 lb, flange horizontal.

LIQUID TEMPERATURE

104°F (40°C) continuous.

VOLUTE

Cast iron ASTM A-48 class 30.

WEAR RING

Bronze.

MOTOR HOUSING

Cast iron ASTM A-48 class 30.

SEAL PLATE

Cast iron ASTM A-48 class 30.

IMPELLER

Design: 1 vane (2 for 48 and 60 HP), closed, with vanes on backside.

Material: cast iron ASTM A-48 class 30.

SHAFT

416 series stainless steel.

SQUARE RINGS

Buna-N.

PAINT

Air dry enamel, water based.

DIAPHRAGM

Buna-N.

HARDWARE

300 series stainless steel.

SEAL

Design: double, mechanical, oil filled chamber.

Material: silicon carbide outboard seal, carbon ceramic inboard seal, Buna-N elastomer and stainless steel hardware.

CORD ENTRY

25 ft of neoprene cord 2/3 G, sealed against moisture.

BEARINGS

Upper: ball, single row, oil lubricated, for radial load.

Lower: ball, single row, oil lubricated, for radial and thrust load.

MOTOR

NEMA B, three phase, 230 & 460 volts, 60 Hz, 1750 RPM, oil filled. Requires overload protection to be included in control panel.

MOISTURE SENSOR

Normally open (N/O) included.

TEMPERATURE SENSOR

Normally closed (N/C) included.

OPTIONAL EQUIPMENT

Impeller trimming, additional cord, tungsten carbide seal, slide rail coupling (SRC-6).

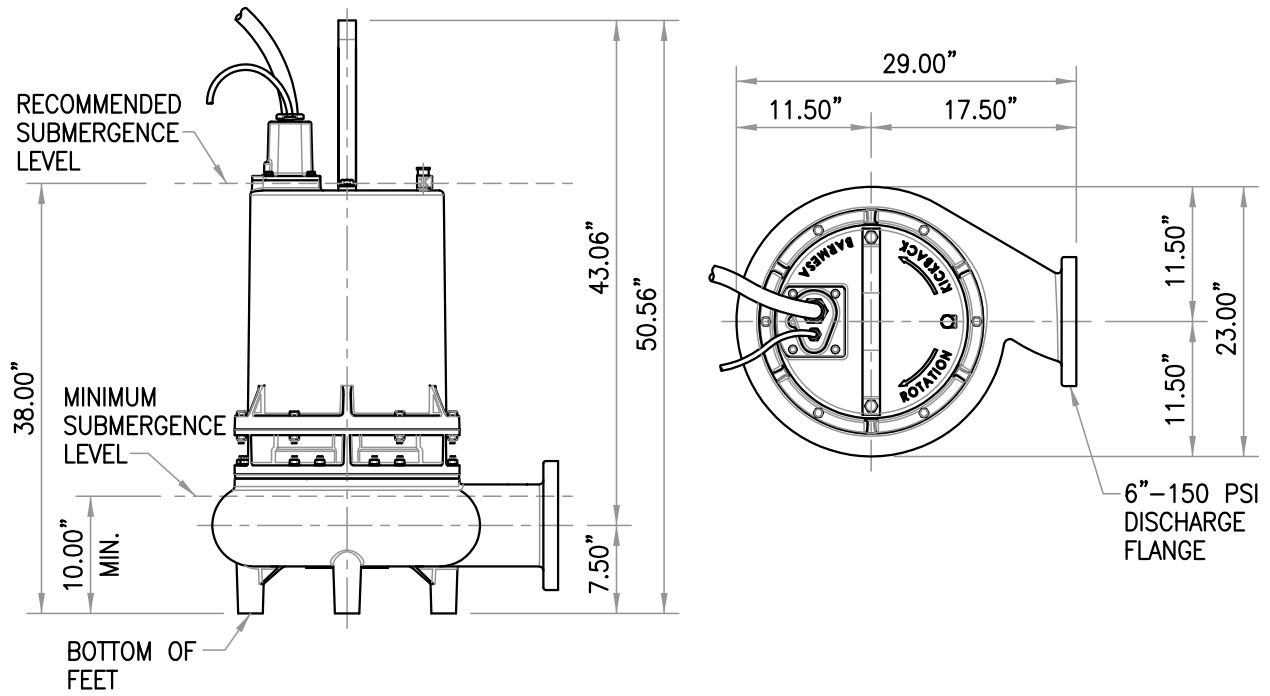

MODEL	PART No.	HP	VOLTS	PHASE	RPM (Nominal)	MAX AMPS	LOCKED ROTOR AMPS	NEMA CODE	CORD SIZE	CORD TYPE	CORD O. D.	WEIGHT (pounds)
6BSE18034LDS	62170206	18	230	3	1750	50.6	232	F	2/3	G	1.34"	891
6BSE18044LDS	62170207	18	460	3	1750	25.3	116	F	2/3	G	1.34"	891
6BSE24034LDS	62170210	24	230	3	1750	62.8	290	E	2/3	G	1.34"	928
6BSE24044LDS	62170211	24	460	3	1750	31.4	145	E	2/3	G	1.34"	928
6BSE30034LDS	62170214	30	230	3	1750	75.8	364	E	2/3	G	1.34"	985
6BSE30044LDS	62170215	30	460	3	1750	37.9	182	E	2/3	G	1.34"	985
6BSE36034LDS	62170231	36	230	3	1750	90	434	E	2/3	G	1.34"	992
6BSE36044LDS	62170232	36	460	3	1750	45	217	E	2/3	G	1.34"	992
6BSE48044LDS	62170220	48	460	3	1750	65	290	E	2/3	G	1.34"	1014
6BSE60044LDS	62170251	60	460	3	1750	78	363	E	2/3	G	1.34"	1052

The moisture cord and/or temperature cord is size 18/5, type SO, Ø0.485", for all models.

IMPORTANT!

1. Never use this pump to handle explosive liquids.
2. This pump is not approved to be used in swimming pools, recreational installations or any application where human contact may be common.
3. Pump may be operated "dry" for extended periods without damage to motor &/or seals.

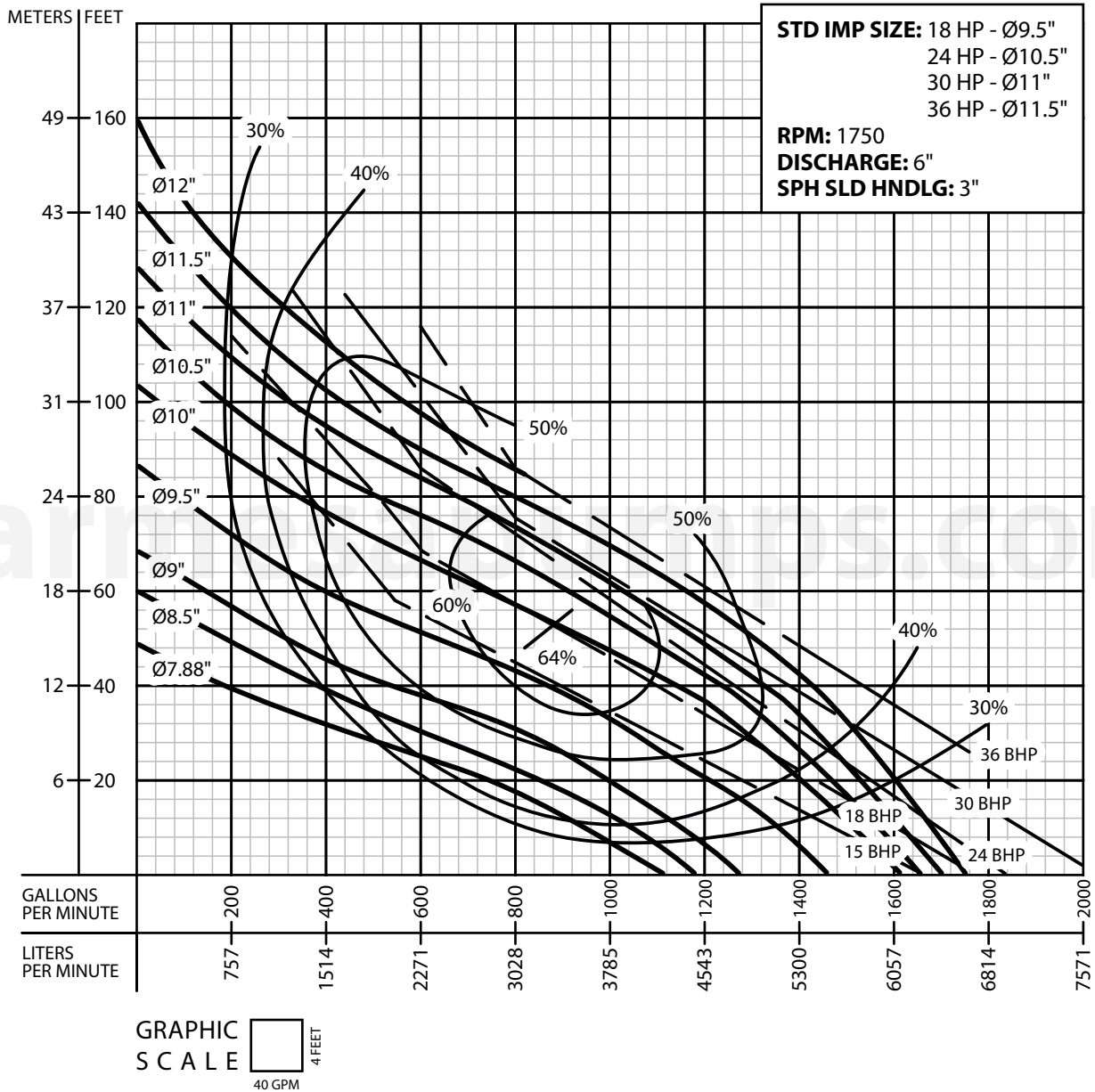

Testing is performed with water specific gravity of 1.0 @ 68 °F (20 °C); other fluids may vary performance.



PERFORMANCE CURVE

Submersible Solids Handling Pump

Series: 6BSE-LDS

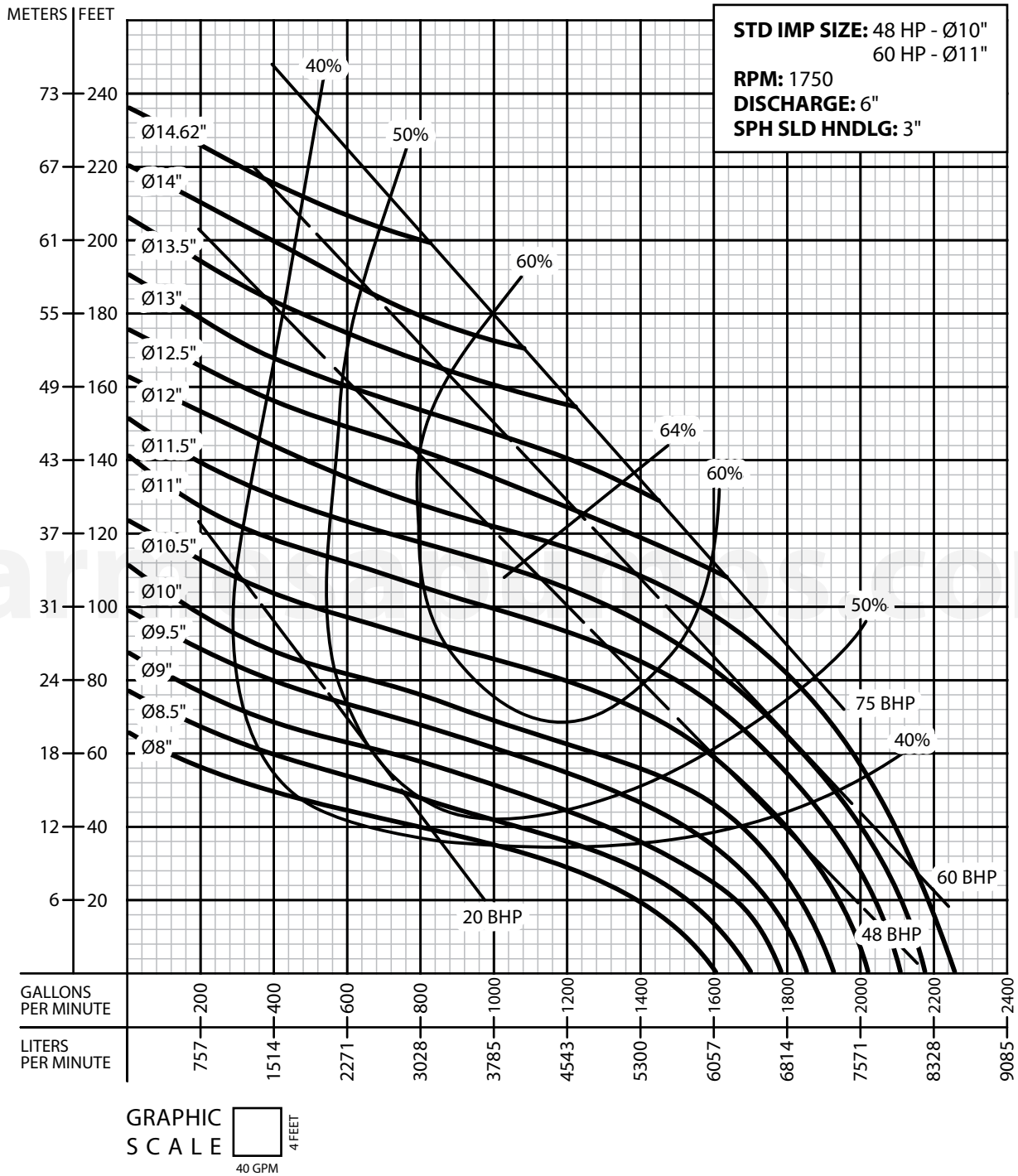

Testing is performed with water specific gravity of 1.0 @ 68 °F (20 °C); other fluids may vary performance.