

2AHS

0.5, 1 & 2 HP
@ 3500 RPM



IMPORTANT! - Read all instructions in this manual before operating or servicing a pump.

Before installation, read the following instructions carefully. Failure to follow instruction and safety information could cause serious bodily injury, death and/or property damage. Each Barmesa product is carefully inspected to insure proper performance. Closely following these instructions will eliminate potential operating problems, assuring years of trouble-free service.

⚠ DANGER Indicates an imminently hazardous situation which, if not avoided, WILL result in death or serious injury.

⚠ WARNING Indicates an imminently hazardous situation which, if not avoided, MAY result in death or serious injury.

⚠ CAUTION Indicates a potentially hazardous situation which, if not avoided, MAY result in minor or moderate injury.

IMPORTANT! - Barmesa Pumps is not responsible for losses, injury or death resulting from failure to observe these safety precautions, misuse, abuse or misapplication of pumps or equipment.

 **ALL RETURNED PRODUCTS MUST BE CLEANED, SANITIZED, OR DECONTAMINATED PRIOR TO SHIPMENT, TO INSURE EMPLOYEES WILL NOT BE EXPOSED TO HEALTH HAZARDS IN HANDLING SAID MATERIAL. ALL APPLICABLE LAWS AND REGULATIONS SHALL APPLY.**

⚠ WARNING Installation, wiring, and junction connections must be in accordance with the National Electric Code and all applicable state and local codes. Requirements may vary depending on usage and location.

⚠ WARNING Installation and servicing is to be conducted by qualified personnel only.

 Keep clear of suction and discharge openings. Do not insert fingers in pump with power connected; the rotating cutter and/or impeller can cause serious injury.

 Always wear eye protection when working on pumps. Do not wear loose clothing that may become entangled in moving parts.

⚠ DANGER Pumps build up heat and pressure during operation. Allow time for pumps to cool before handling or servicing the pump or any accessory items associated with or near the pump.

⚠ DANGER This pump is not intended for use in swimming pools or water installations where there is human contact with pumped fluid.

⚠ DANGER Risk of electric shock. To reduce risk of electric shock, always disconnect pump from power source before handling any aspect of the pumping system. **Lock out power & tag.**

⚠ WARNING Do not use these pumps in water over 104 °F. Do not exceed manufactures recommended maximum performance, as this could cause the motor to overheat.

⚠ DANGER Do not lift, carry or hang pump by the electrical cables. Damage to the electrical cables can cause shock, burns or death. **Never** handle connected power cords with wet hands. Use appropriate lifting device.

⚠ WARNING Ground Fault Circuit Interrupter (GFCI) to be used with plug-in type power cord.

⚠ DANGER Failure to permanently ground the pump, motor and controls before connecting to power can cause shock, burns or death.

⚠ DANGER These pumps are not to be installed in locations classified as hazardous in accordance with the National Electric Code, ANSI/NFPA 70.

⚠ WARNING The Uniform Plumbing Code (UPC) states that sewage systems shall have an audio and visual alarm that signals a malfunction of the systems, that are required to reduce the potential for property damage.

IMPORTANT! - Prior to installation, record Model Number, Serial, Amps, Voltage, Phase and HP from pump name plate for the future reference. Also record the Voltage and Current Readings at Startup:

Model Number: _____

Serial: _____

Amps: _____ Volts: _____

Phase: _____ HP: _____

- DISCHARGE:** 2" NPT, vertical, adapter included.
- SPHERICAL SLD HNDLG:** 1/2"
- LIQUID TEMPERATURE:** 104 °F (40 °C) max.
- PUMP BODY:** Cast iron FC-200.
- MOTOR HOUSING:** Aluminum alloy ADC12.
- OIL CHAMBER:** Cast iron FC-200.
- IMPELLER:** 8 vane, semi-open *Vortex*. Hytrel® thermoplastic elastomer.
- SHAFT:** 410 series stainless steel.
- HARDWARE:** 304 series stainless steel.
- O-RINGS:** Nitrile rubber (NBR).
- PAINT:** Air dry enamel, water based.
- SEAL:** Double mechanical, oil filled chamber. Upper part of carbon-ceramic, lower part of silicone carbide. Stainless steel hardware.
- CORD ENTRY:** 15 ft of neoprene cord, sealed against moisture.
- BEARINGS:** Ball, single row, permanently oil lubricated for 60,000 hours of work. Designed for radial and axial loads.
- MOTOR:** Dry type submersible motor, 1 & 3 phase, 115 & 230 volts, 60 Hz, 3500 RPM. For continuous duty, with thermal protector IP68 in winding, insulation class B.
- STRAINER:** Polyvinyl chloride (PVC).
- HANDLE:** Nylon 6.
- PUMP OPERATION:** Available as "A" Automatic model or Manual operation (no level control).

MODEL	PART No.	HP	VOLTS	PHASE	RPM (Nominal)	MAX AMPS	CORD SIZE	A	B	C	D	E	WEIGHT (pounds)
2AHS051	62180101	0.5	115	1	3500	6	16AWG/3C	13.86"	9.57"	Ø7"	4.25"	4.61"	27
2AHS051A	62180102												28
2AHS101	62180103	1	115	1	3500	12	16 AWG/3C	14.84"	10.98"	Ø7"	4.75"	5.24"	33
2AHS101A	62180104												34
2AHS103	70090005	1	230	3	3500	3	16 AWG/3C	14.84"	10.98"	Ø7"	4.75"	5.24"	34
2AHS203	70090007	2	230	3	3500	7	14 AWG/3C	18.27"	12.32"	Ø7.5"	5.13"	6.1"	42

A = Automatic Float Switch. A control panel is needed for the 3 phase pumps to operate in automatic.

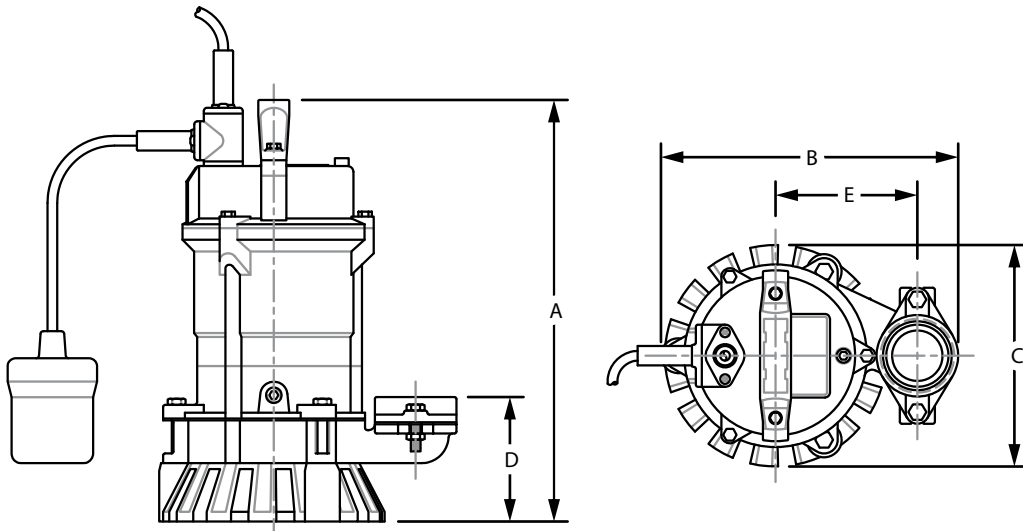

► Receiving inspection

Upon receiving the pump, it should be inspected for damage or shortages. If damage has occurred, file a claim immediately with the company that delivered the pump. If the manual is removed from the packaging, do not lose or misplace.

► Storage

Any product that is stored for a period longer than six (6) months from the date of purchase should be bench tested prior to installation. A bench test consists of, checking the impeller to assure it is free turning and a run test to assure the motor (and switch if provided) operate properly.

► Before Installation

Insulation resistance measurement

With the motor and cable (excluding the power supply cable) immersed in water, use a megger to measure the insulation resistance between ground and each phase of the motor, and again between each phase of the motor. The megger should indicate an insulation resistance of not less than 20 mega ohms. While making the measurement, keep the power supply cable off the ground. **We recommend that an auxiliary pump be kept on hand in case of emergency.**

► Installation

⚠ WARNING Under no circumstances should cable be pulled while the pump is being transported or installed. Attach a chain or rope to the grip and install the pump.

1. This pump must not be installed on its side or operated in a dry condition. Ensure that it is installed upright on a secure base.
2. Install the pump at a location in the tank where there is the least turbulence.

3. If there is a flow of liquid inside the tank, support the piping where appropriate. Install piping so that air will not be entrapped. If piping must be installed in such a way that air pockets are unavoidable, install an air release valve wherever such air pockets are most likely to develop.

4. Do not permit end of discharge piping to be submerged, as backflow will result when the pump is shut down.

⚠ WARNING Non-automatic pumps (models 2AHS), have an automatic operating system bump operating water level near the minimum operating level as the automatic cut-off switch incorporated inside the motor will be activated. To avoid dry operation, install an automatic operating system, as shown in Figure 1 and maintain a safe operating water level (C.W.L.: continuous water level = 90 mm).

5. For automatic pumps (models 2AHS-A), install the floats as shown in figure 2. The pump may not start if a floats switch touches the wall of the water tank or the piping. Install the floats so that this will not happen.

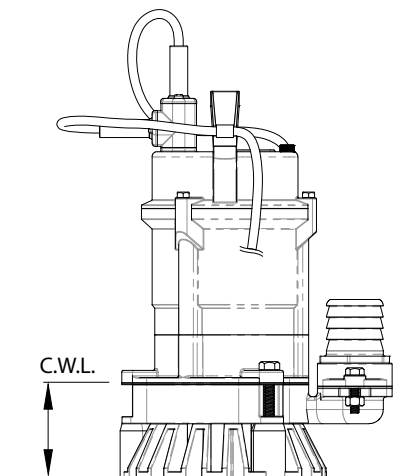

Figure 1

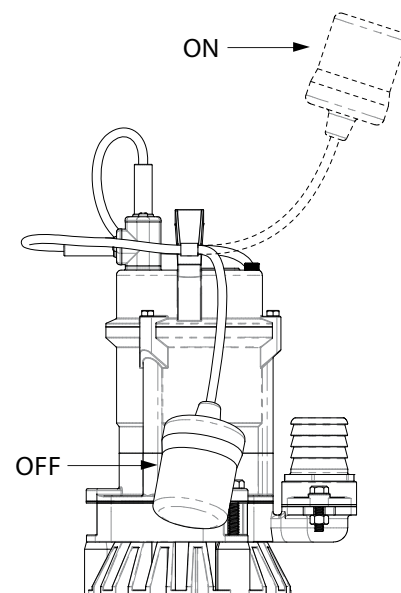

Figure 2

Wiring:

- a) Wire as indicated for the appropriate start system as shown in figure 3.
- b) Loose connections will stop the pump. Make sure all electrical connections are secure.

Cable:

- ⚠ WARNING**
- c) Never let the end of the cable contact water.
 - d) If the cable is extended, do not immerse the splice in water.
 - e) Fasten the cable to the discharge piping with tape or vinyl strips.
 - f) Install the cable so that it will not overheat. Overheating caused by coiling the cable and exposing it to direct sunlight.

Grounding:

Connect the green wire to ground. Under no circumstances should the green wire be connected to the power supply.

⚠ DANGER Use short circuit breakers to prevent danger of electrical shock.



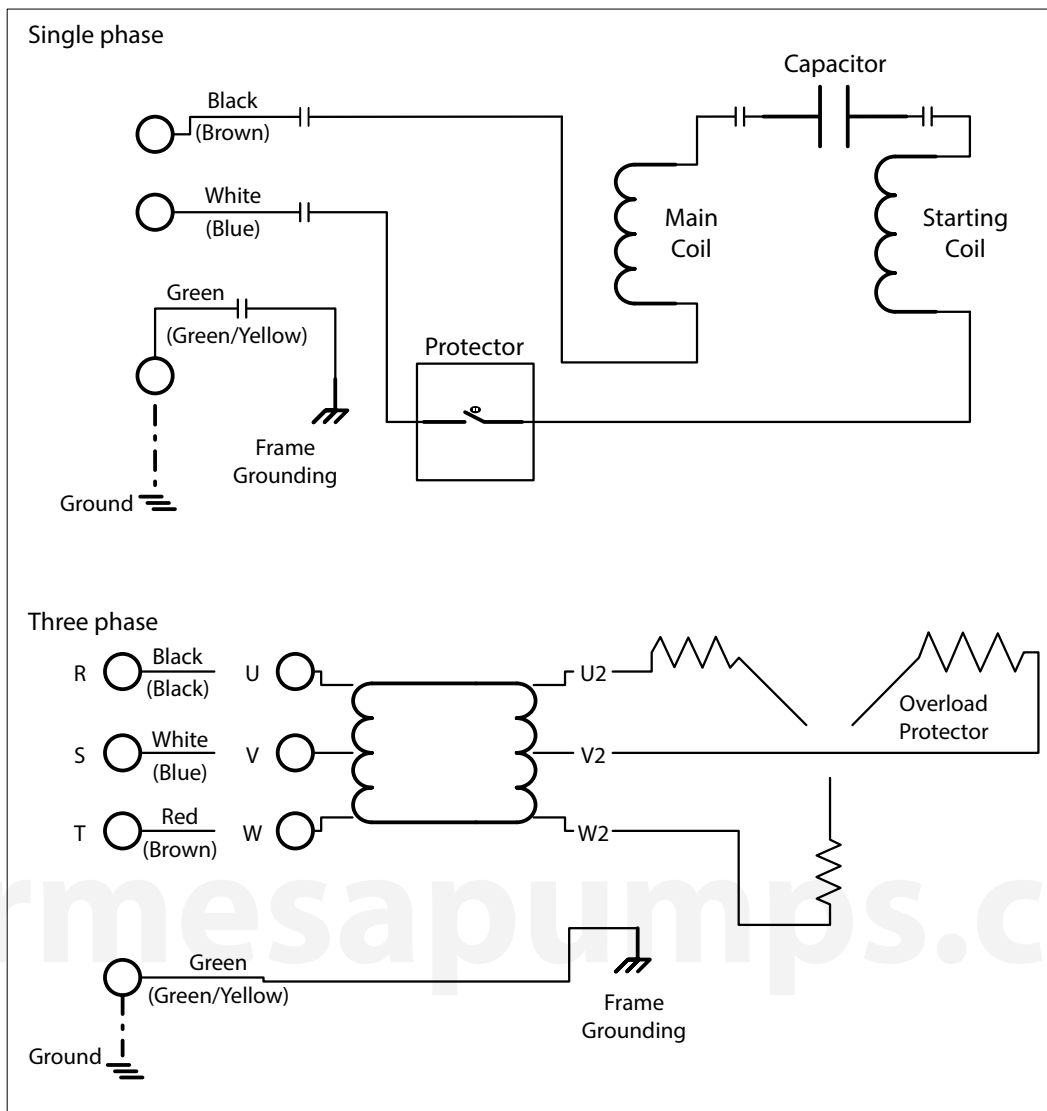

Figure 3

► Before Starting the Pump

- 1) After completing installation, measure the insulation resistance again as described in Installation.
- 2) Check water level. If the pump is operated continuously for an extended period of time in a dry condition or at the lowest water level, the motor protector will be activated. Constant repetition of this action will shorten pump service life. Do not start the pump again in such a situation until after the motor has completely cooled.

► Test operation

Automatic (2AHS-A) and non-automatic (2AHS) pump:

- 1) Turn the operating switch on and off a couple of times to check for normal pump start.

For the 2AHS-A:

- Floating switch must be raised for the pump to start.
- 2) Next, check direction and rotation. If discharge volume is low or unusual sounds are heard when the pump is operating, rotation has been reversed. When this happens, reverse two of the wires.

► Maintenance



Check pressure, output, voltage, current and other specifications. Unusual readings may indicate. Refer to Troubleshooting and correct as soon as possible.

Daily inspections:

- 1) Check current and ammeter fluctuation daily. If ammeter fluctuation is high, even though within the limits of pump rating, foreign matter may be clogging the pump. If the quantity of liquid discharged falls suddenly, foreign matter may be blocking the suction inlet.

Monthly inspections:

Measure the insulation resistance. The value should be more than 1M ohm. If resistance starts to fall rapidly even with an initial indication of over 1M ohm, this may be an indication of trouble and repair work is required.

Annual inspections:

To extend the service life of the mechanical seal, replace the oil in the mechanical seal chamber once a year. Water mixed with the oil or cloudy textures are indications of a defective mechanical seal requiring replacement. When replacing the oil, lay the pump on its side with filler plug on top. Inject suitable amount turbine oil no. 32 (ISO VG-32).

Inspections at 3-5 year intervals:

Conduct an overhaul of the pump. These intervals will preclude the possibility of future trouble.

Parts that will need to be replaced:

Replace the appropriate part when the following conditions are apparent. See Table 1. (Note: replacement schedule is based on normal operating conditions)

► Disassembly

When disassembling pump, have a piece of cardboard or wooden board ready to place the different parts on as you work. Do not pile parts on top of each other. They should be laid out neatly in rows. The o-ring and gasket cannot be used again once they are removed. Have replacement parts ready. Disassemble in the following order, referring to the sectional view.

⚠ WARNING Be sure to cut off power source before disassembly.

1. Remove pump casing bolts, raise the motor section and remove pump casing.
2. Remove shaft head bolt and impeller.
3. Remove oil filler plug and drain lubricating oil.
4. Remove intermediate casing bolts and intermediate oil chamber. (Remember that any lubricating oil remaining in the mechanical seal chamber will flow out.)
5. Carefully remove mechanical seal, taking care not to scratch sliding surface or motor shaft.

► Assembly

Re-assemble in reverse order of disassembly. Be careful of the following points:

6. During re-assembly, rotate the impeller by hand and check for smooth rotation. If rotation is not smooth, perform steps (3) through (5) again.
7. Upon completion of re-assembly step 1 rotate the impeller by hand from the suction the suction inlet and check that it rotates smoothly without touching the suction cover before operating the pump.

Please obtain o-rings, packing, shaft seals and other parts from pump dealer.

Table 1

REPLACEABLE PART	Mechanical seal	Oil filler plug gasket	Lubricating oil	O-ring
REPLACEMENT GUIDE	Whenever oil in mechanical seal chamber is clouded	Whenever oil is replaced or inspected	Whenever clouded or dirty	Whenever pump is overhauled
FREQUENCY	Annually	Every 6 months	Every 6 months	Annually

Figure 4

▶ 2AHS 0.5 HP

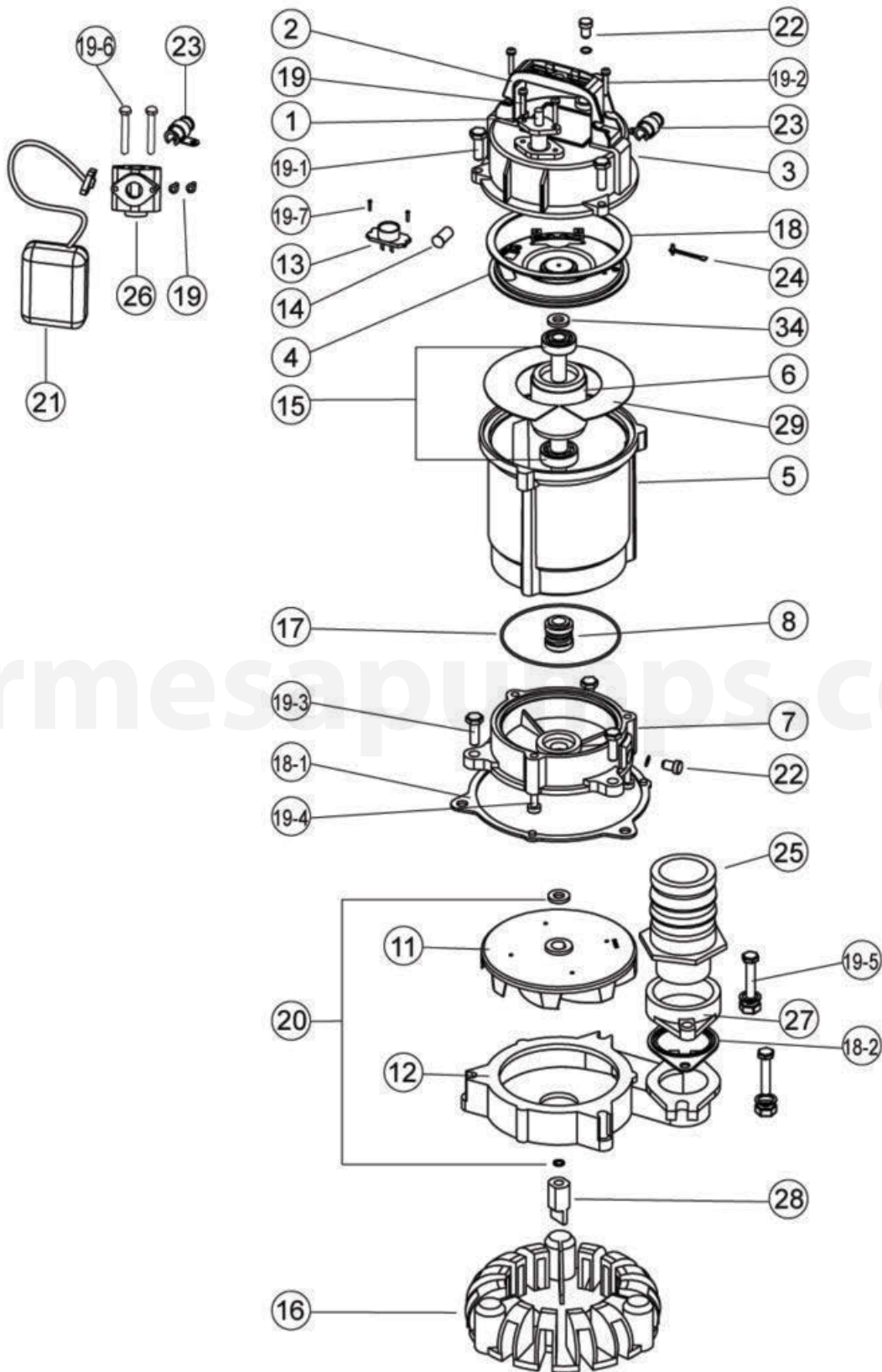

For repair part please supply: Model Number and Serial as shown on Name Plate, and Part Description and Part Number as shown on Parts List.

► 2AHS 0.5 HP

ITEM	NAME	MATERIAL	PHOTO	ITEM	NAME	MATERIAL	PHOTO
1	CABLE	H07/UL		13	PROTECTOR (1 PHASE)		 (OPTIONAL)
2	HANDLE	NYLON 6		13	PROTECTOR (3 PHASE)		
3	MOTOR COVER	ADC12		14	CAPACITOR		
4	BRACKET	SECC		15	BEARING		
5	MOTOR HOUSING + STATOR	ADC12		16	STRAINER	PVC	
6	SHAFT WITH ROTOR	SUS410		17	O-RING	NBR	
7	OIL CHAMBER	CAST IRON		21	FLOAT SWITCH (OPTIONAL)		
8	MECHANICAL SEAL	UPPER: CA/CE LOWER: SIC/SIC		25	PLASTIC HOSETAIL		
11	IMPELLER	HYTREL		27	FLANGE	FC-15	
12	PUMP CASING	CAST IRON		28	AGITATOR	SMF5030	

ITEM	NAME	MATERIAL	ITEM	NAME	MATERIAL
18	GASKET	NBR	19-6	SCREW	SUS 304
18-1	GASKET	NBR	19-7	SCREW	SUS 304
18-2	GASKET	NBR	20	WASHER	SUS 304
19	SCREW	SUS 304	22	SCREW WITH O-RING	
19-1	SCREW	SUS 304	23	CABLE SEAT	
19-2	SCREW	SUS 304	24	EARTH LINE AND SCREW	
19-3	SCREW	SUS 304	26	"T" ADAPTER (OPTIONAL)	
19-4	SCREW	STEEL	29	INSULATING PAPER	
19-5	SCREW	SUS 304	34	CORRUGATED SPRING	STEEL

For repair part please supply: Model Number and Serial as shown on Name Plate, and Part Description and Part Number as shown on Parts List.

Figure 5

▶ 2AHS 1 HP

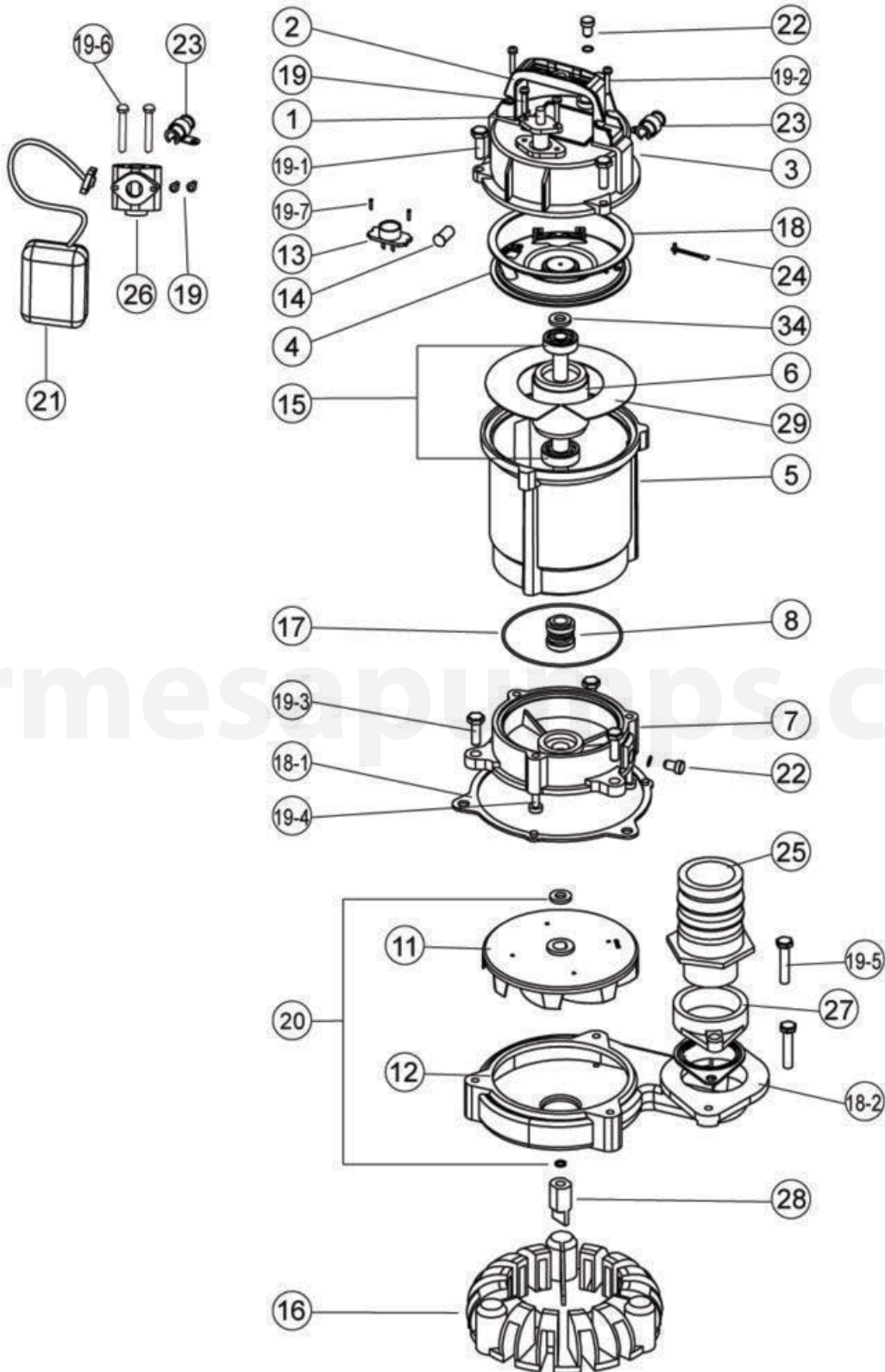

For repair part please supply: Model Number and Serial as shown on Name Plate, and Part Description and Part Number as shown on Parts List.

► 2AHS 1 HP

ITEM	NAME	MATERIAL	PHOTO	ITEM	NAME	MATERIAL	PHOTO
1	CABLE	H07/UL		13	PROTECTOR (1 PHASE)		 (OPTIONAL)
2	HANDLE	NYLON 6		13	PROTECTOR (3 PHASE)		
3	MOTOR COVER	ADC12		14	CAPACITOR		
4	BRACKET	SECC		15	BEARING		
5	MOTOR HOUSING + STATOR	ADC12		16	STRAINER	PVC	
6	SHAFT WITH ROTOR	SUS410		17	O-RING	NBR	
7	OIL CHAMBER	CAST IRON		21	FLOAT SWITCH (OPTIONAL)		
8	MECHANICAL SEAL	UPPER: CA/CE LOWER: SIC/SIC		25	PLASTIC HOSETAIL		
11	IMPELLER	HYTREL		27	FLANGE	FC-15	
12	PUMP CASING	CAST IRON		28	AGITATOR	SMF5030	

ITEM	NAME	MATERIAL	ITEM	NAME	MATERIAL
18	GASKET	NBR	19-6	SCREW	SUS 304
18-1	GASKET	NBR	19-7	SCREW	SUS 304
18-2	GASKET	NBR	20	WASHER	SUS 304
19	SCREW	SUS 304	22	SCREW WITH O-RING	
19-1	SCREW	SUS 304	23	CABLE SEAT	
19-2	SCREW	SUS 304	24	EARTH LINE AND SCREW	
19-3	SCREW	SUS 304	26	"T" ADAPTER (OPTIONAL)	
19-4	SCREW	STEEL	29	INSULATING PAPER	
19-5	SCREW	SUS 304	34	CORRUGATED SPRING	STEEL

For repair part please supply: Model Number and Serial as shown on Name Plate, and Part Description and Part Number as shown on Parts List.

Figure 6

▶ 2AHS 2 HP

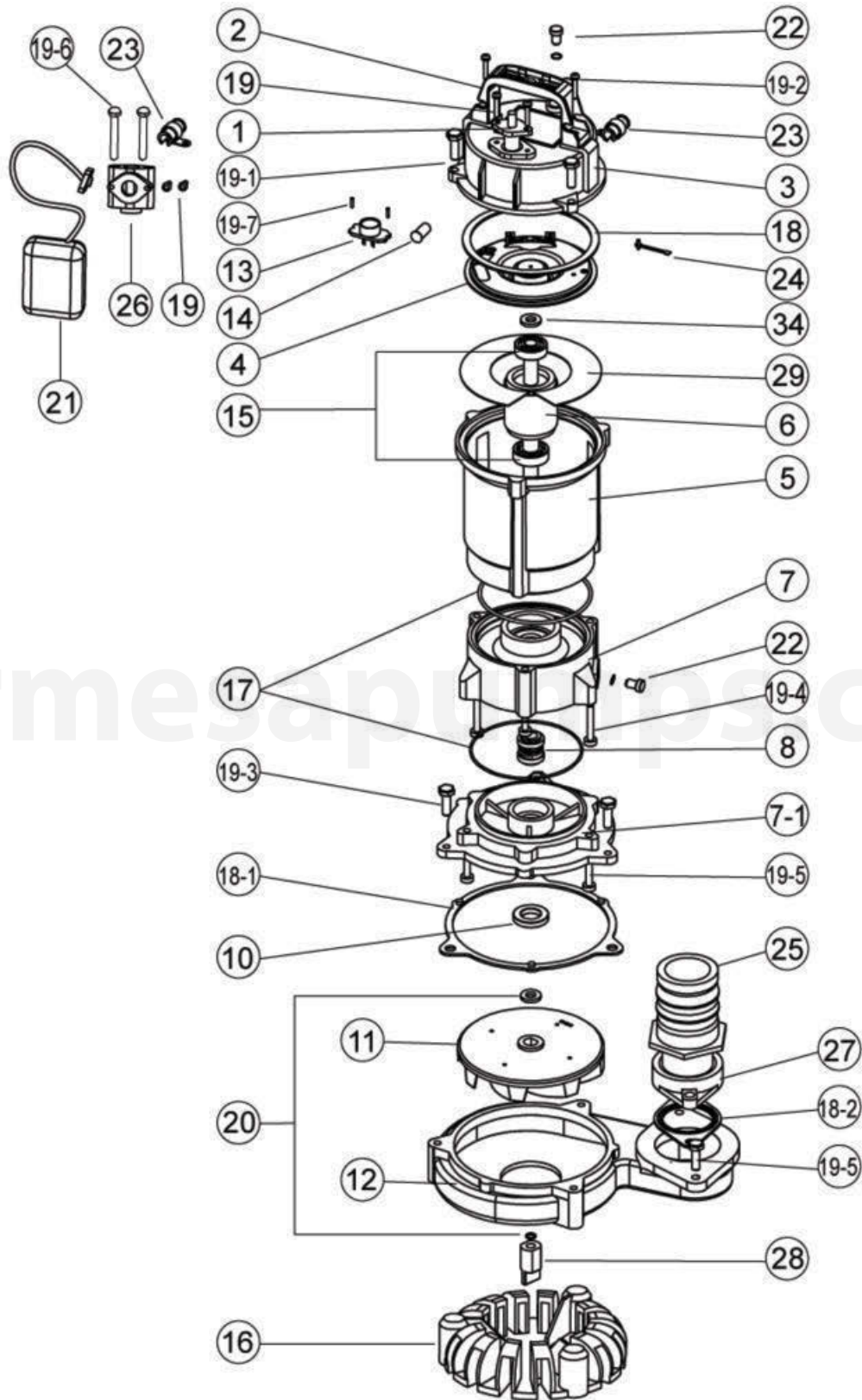

For repair part please supply: Model Number and Serial as shown on Name Plate, and Part Description and Part Number as shown on Parts List.

▶ 2AHS 2 HP

ITEM	NAME	MATERIAL	PHOTO	ITEM	NAME	MATERIAL	PHOTO
1	CABLE	H07/UL		12	PUMP CASING	CAST IRON	
2	HANDLE	NYLON 6		13	PROTECTOR (1 PHASE)		 (OPTIONAL)
3	MOTOR COVER	ADC12		13	PROTECTOR (3 PHASE)		
4	BRACKET	SECC		14	CAPACITOR		
5	MOTOR HOUSING + STATOR	ADC12		15	BEARING		
6	SHAFT WITH ROTOR	SUS410		16	STRAINER	PVC	
7	OIL CHAMBER A	A356		17	O-RING	NBR	
7-1	OIL CHAMBER B	A356		21	FLOAT SWITCH (OPTIONAL)		
8	MECHANICAL SEAL	UPPER: CA/CE LOWER: SIC/SIC		25	PLASTIC HOSETAIL		
10	OIL SEAL	NBR		27	FLANGE	FC-15	
11	IMPELLER	HYTREL		28	AGITATOR	SMF5030	

ITEM	NAME	MATERIAL	ITEM	NAME	MATERIAL
18	GASKET	NBR	19-6	SCREW	SUS 304
18-1	GASKET	NBR	19-7	SCREW	SUS 304
18-2	GASKET	NBR	20	WASHER	SUS 304
19	SCREW	SUS 304	22	SCREW WITH O-RING	
19-1	SCREW	SUS 304	23	CABLE SEAT	
19-2	SCREW	SUS 304	24	EARTH LINE AND SCREW	
19-3	SCREW	SUS 304	26	"T" ADAPTER (OPTIONAL)	
19-4	SCREW	STEEL	29	INSULATING PAPER	
19-5	SCREW	SUS 304	34	CORRUGATED SPRING	STEEL

For repair part please supply: Model Number and Serial as shown on Name Plate, and Part Description and Part Number as shown on Parts List.



Risk of electric shock. Always disconnect the pump from the power source before handling inspections or repairs.

Symptom	Possible Cause(s)	Corrective Action
Does not start. Starts, but immediately stops.	(1) Power failure (2) Large discrepancy between power source and voltage (3) Significant drop in voltage (4) Motor phase malfunction (5) Electric circuit connection faulty (6) Faulty connection of control circuit (7) Fuses is blown (8) Faulty magnetic switch (9) Water is not at level indicated by float (10) Float is not in appropriate level (11) Float is not effective (12) Short circuit breaker is functioning (13) Foreign matter clogging pump (14) Motor burned out (15) Motor bearing broken	(1)~(3) Contact electric power company and devise counter-measures (4) Inspect electric circuit (5) Correct wiring (6) Inspect connections and magnetic coil (7) Check circuit then replace fuse (8) Replace with correct one (9) Raise water level (10) Adjust the position of float (11) Repair or replace (12) Repair location of short circuit (13) Remove foreign matter (14) Repair or replace (15) Repair or replace
Operates, but stops after a while.	(1) Prolonged dry operation has activated motor protector and caused pump to stop (2) High liquid temperature has activated motor protector and caused pump to stop (3) Reverse rotation	(1) Raise water level to C.W.L. (2) Lower liquid temperature (3) Correct rotation
Does not pump. Inadequate volume.	(1) Reverse rotation (2) Significant drop in voltage (3) Operating a 60 Hz pump with 50 Hz (4) Discharge head is high (5) Large piping loss (6) Low operating water level causes air suction (7) Leaking from discharge piping (8) Clogging of discharge piping (9) Foreign matter in suction inlet (10) Foreign matter clogging pump (11) Worn impeller	(1) Correct rotation (see Operation) (2) Contact electric power company (3) Check nameplate (4) Recalculate and adjust (5) Recalculate and adjust (6) Raise water level or lower pump (7) Inspect, repair (8) Remove foreign matter (9) Remove foreign matter (10) Remove foreign matter (11) Replace impeller
Over current.	(1) Unbalanced current and voltage (2) Significant voltage drop (3) Motor phase malfunction (4) Operating 50 Hz pump on 60 Hz (5) Reverse rotation (6) Low head. Excessive volume of water (7) Foreign matter clogging pump (8) Motor bearing is worn out or damaged	(1) Contact electric power company (2) Contact electric power company and devise counter-measure (3) Inspect connections and magnetic switch (4) Check nameplate (5) Correct rotation (see Operation 2) (6) Replace pump with high head pump (7) Remove foreign matter (8) Replace bearing
Pump vibrates; excessive operating noise.	(1) Reverse rotation (2) Pump clogged with foreign matter (3) Piping resonates (4) Strainer is closed too far	(1) Correct rotation (2) Disassemble and remove foreign matter (3) Improve piping (4) Open strainer

NOTE: Barmesa Pumps assumes no responsibility for damage or injury due to disassembly in the field. Disassembly of the pumps or supplied accessories other than at Barmesa Pumps or its authorized service centers, automatically voids warranty.

BARMESA PUMPS FACTORY WARRANTY

Barmesa Pumps warrants that products of our manufacture will be free of defects in material and workmanship under normal use and service for 18 months from date of manufacture or 12 months from installation date whichever occurs first. This warranty gives you specific legal rights, which vary from state to state.

This warranty is a limited warranty, and no warranty related claims of any nature whatsoever shall be made against Barmesa Pumps, until the ultimate consumer or his/her successor notifies us in writing of the defect and delivers the product and/or defective part(s) freight prepaid to our factory or nearest authorized service station as instructed by Barmesa Pumps. THERE SHALL BE NO FURTHER LIABILITY, WHETHER BASED ON WARRANTY, NEGLIGENCE OR OTHERWISE. PRODUCT SHALL BE EITHER REPLACED OR REPAIRED AT THE ELECTION OF BARMESA PUMPS. Guarantees relating to performance specifications provided in addition to the foregoing material and workmanship warranties on a product manufactured by Barmesa Pumps, if any, are subject to possible factory testing. Any additional guarantees, in the nature of certified performance specifications or time frame must be in writing and such writing must be signed by our authorized factory manager at time of order placement and/or at time of quotation. Due to inaccuracies in field testing and should a conflict arises between the results of field testing conducted by or for the user, Barmesa Pumps reserves the right to have the product returned to our factory for additional testing.

This warranty shall not apply when damage is caused by (1) improper installation, (2) improper voltage, (3) lightning, (4) excessive sand or other abrasive material, (5) corrosion build-up due to excessive chemical content or (6) uncontrollable acts of god. Any modification of the original equipment will also void the warranty. We will not be responsible for loss, damage or labor cost due to interruption of service caused by defective pumps, parts or systems. Barmesa Pumps will not accept charges incurred by others without our prior written approval.

This warranty is void if our inspection reveals the product was used in a manner inconsistent with normal industry practice and/or our specific recommendations. The purchaser is responsible for communication of all necessary information regarding the application and use of the product. UNDER NO CIRCUMSTANCES WILL WE BE RESPONSIBLE FOR ANY OTHER DIRECT OR CONSEQUENTIAL DAMAGES, INCLUDING BUT NOT LIMITED TO TRAVEL EXPENSES, CONTRACTOR FEES, UNAUTHORIZED REPAIR SHOP EXPENSES, LOST PROFITS, LOST INCOME, LABOR CHARGES, DELAYS IN PRODUCTION, IDLE PRODUCTION, WHICH DAMAGES ARE CAUSED BY ANY DEFECTS IN MATERIAL AND/OR WORKMANSHIP AND/OR DAMAGE OR DELAYS IN SHIPMENT. THIS WARRANTY IS EXPRESSLY IN LIEU OF ANY OTHER EXPRESS OR IMPLIED WARRANTY. No rights extended under this warranty shall be assigned to any other person, whether by operation of law or otherwise, without our prior written approval.

IMPORTANT!

If you have a claim under the provision of the warranty, contact Barmesa Pumps or your authorized Barmesa Pumps Distributor:
warranty@barmesapumps.com
www.barmesapumps.com



Barmesa[®]
Pumps

