

911 SERIES



IMPORTANT! - Read all instructions in this manual before operating or servicing a pump.

BARMESA process pump series 911 is a centrifugal pump with horizontal suction and vertical discharge, open impeller, which meets ANSI B73.1 requirements. It is made of the best materials and components, with continuous inspection, ensuring high quality. Through proper installation periodic inspection, monitoring its condition and careful maintenance, this pump will give you satisfying and lasting service. Maintenance operators must realize this and follow the appropriate safety precautions. This manual provides information for installation, preventive maintenance, troubleshooting and corrections, and the part list.

It is important to consider the following:

1. Always be sure to disconnect engine electric current power before performing maintenance to the pump.
2. Never operate the pump in conditions beyond those with which the pump was sold.
3. Never operate the pump without the flexible coupling guard
4. Never apply heat to disassemble the pump or remove the drive, It can explode due to trapped fluid.
5. Never operate the pump without safety devices.
6. Never operate the pump with the discharge and/or suction valve closed.
7. Never start the pump without priming.

► Specifications

Volute: in horizontal suction and vertical discharge, foot design makes it resistant to slippage and the distortion due to piping loads. Packing is fully confined, the standard layout is serrated flanges with flat face, ASME/ANSI B16.5, for 150#, there are other alternatives such as: 150#RF, 300#FF and 300#RF.

Impeller: fully open and threaded to the drive shaft, thread is isolated from the fluid pumped by teflon ring.

Seal plate: manufactured in iron or stainless steel 316, machined to totally seal with the volute gaskets.

Adaptor: made of iron, with a machined socket to hold the volute and the seal plate, having holes to fit the bearings box.

Shaft: it is made of 4140 steel, comes with adjustable bearing set. This shaft can also be supplied in 316 stainless and in this case it requires no sleeve.

Bearing box: rigid construction and requires no additional machining, to make lubrication oil to grease or oil mist, has a sight glass to check the oil level, the box is sealed using INPRO labyrinth seal "VBX". This bearing box is made of iron for models 911M and 911L has two bearings box support sizes; according to the suction lift the support size is selected.

Bearing support: made of iron material, slot holes for lubrication with oil, grease or oil mist.

Outer bearing: located in the bearing support, it is a two angular contact ball and its design is suitable to support combined load, meaning axial and radial loads acting simultaneously.

Bearing interior: a rigid single row bearings, simple design, suitable for high operating speeds besides requiring little service attention.

Data plate: each pump has a plate identification, which provides information about: model, pump size impeller diameter, building materials, serial No., etc. (see Figure1); the plate is located on the frame. When requiring spare parts please identify the pump model, size, serial, number, plus the number of required parts.

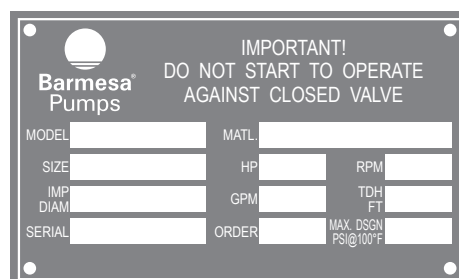

Figure 1

► Pump reception

Upon receiving of the pump, it is important to verify that there is no missing parts/components and has not suffered any damage.

Any claim for shortage or management should be directed to the transportation company. This pump is rigid and heavy lifting equipment must be able to adequately support the entire assembly. Lift pump using a suitable sling (see figures 2 and 3) are examples of proper lifting of these pumps.

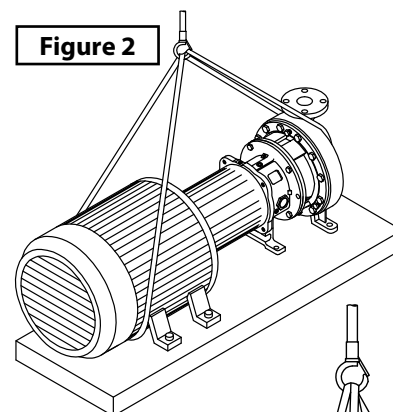

Figure 2

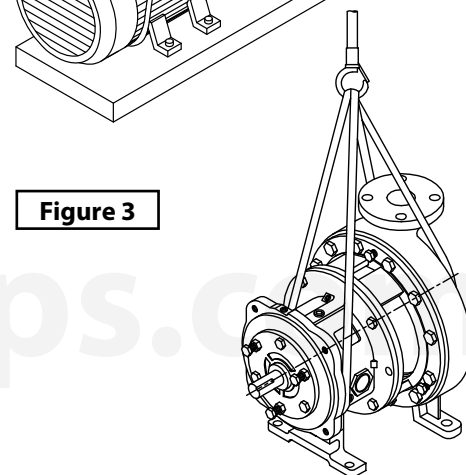

Figure 3

► Pump installation

All pumping equipment should be installed as close as possible to the source of liquid being pumped, in addition to a base that is able to absorb vibrations generated during the operation of the pump, this facility should be located in a space so that the work of operation, maintenance and repair can be performed properly and without risk of equipment damage or personal injury.

► Base plate foundation and leveling

Foundation: a good foundation is made by pouring concrete in the location area of the base plate, the type of anchor is usually sleeve type, since this allows a movement of the basis for the final adjustment. In Fig. 4 and 5 two types of anchoring are shown:

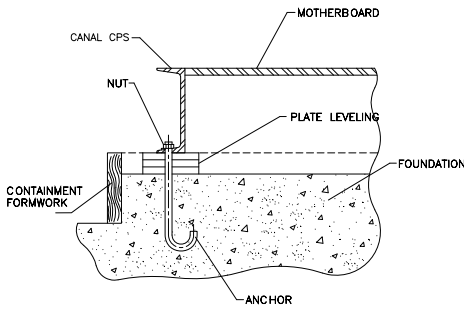

Figure 4

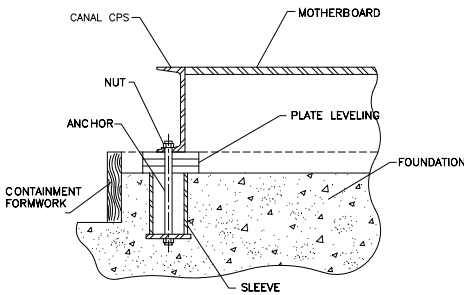

Figure 5

Leveling: (see figure 6 and 7)

- Shall have two sets of shims on the sides of each anchor to reach a height of 1½" above the work floor level, and allow the appropriate application of pouring concrete, plus a uniform settle in the base plate, once the concrete is emptied.
- If you use anchor sleeve, remove the waste solids or liquids of the interior of each anchor sleeve and insert paper or rag to prevent them from filling with concrete when pouring.
- Carefully install the base plate, ensuring that all anchors fit together into their respective holes, and sit on the shims evenly.
- Level the base with a tolerance of 1/8" (3.17 mm) length and 1/16" (1.58 mm) width, adjusting shims.
- Install nuts, tightening them by hand. Once aligned the motherboard, the next step is the pump.

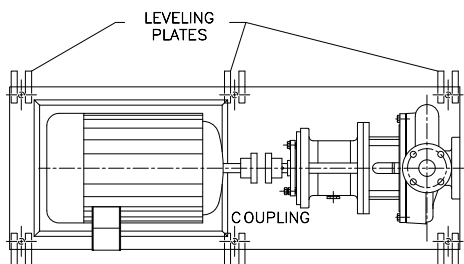

Figure 6

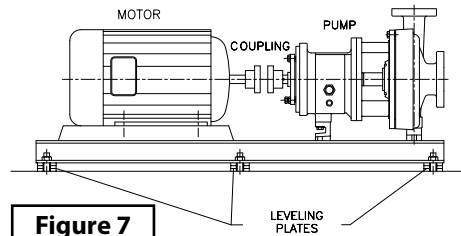

Figure 7

Alignment procedure

Initial alignment: this is done before putting into operation the pump and is divided into three stages:

- Y Before pouring the concrete: To ensure base plate alignment, seen in the leveling section, subsections C and D.
- Y After pouring the concrete: in order to ensure that there are no sudden movements or abnormal contractions of concrete during casting.
- Y After connecting the pipes: checking that the stress on the pipeline have not altered the alignment, if any misalignment, modify the suction and discharge support system to reduce the stress in the flange of the pump.

Final alignment: after the first pump operation the alignment should be checked to ensure that everything is in order, starting from this, you should check the alignment periodically, to maximize the pump performance. A unit is in proper alignment when the angular and parallel alignment readings do not exceed 0.002" (0.05 mm). Here we present some criteria and suggestions for achieving a proper alignment.

Angular alignment.

Vertical: Consists of installing a dial indicator (see Figure 8) in the top half of the coupling "X" leaving it fixed, then coupling "Y" is halfway rotated. If reading exceed 0.002" (0.05 mm), this means that the motor is offset from the top down, install shims at the motor feet to correct the readings.

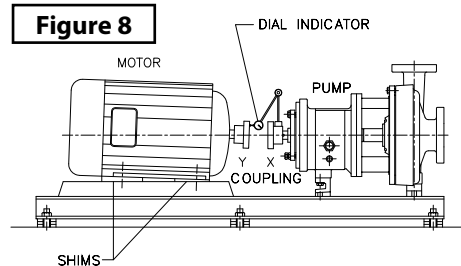

Figure 8

Horizontal: Consist of installing a dial indicator (see Figure 9) in the top half of the coupling "X" leaving it fixed, then coupling "Y" is halfway rotated. If the readings exceed 0.002" (0.05 mm), this means that the motor is offset from the top down, install shims at the motor feet to correct the readings.

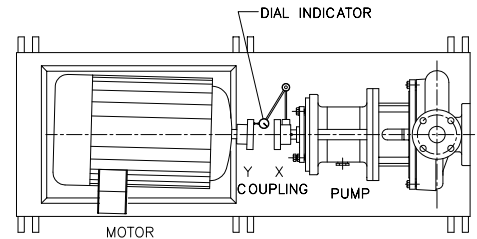

Figure 9

Parallel alignment.

Vertical: Consist of installing a dial indicator (see Figure 10) in the top half of the coupling "X" leaving it fixed, and four cardinal points in the half of the "Y" coupling are inspected. If readings exceed 0.002" (0.05mm), means that the motor is offset from the top down, install or remove equal amounts of shims at the motor feet, to correct the readings.

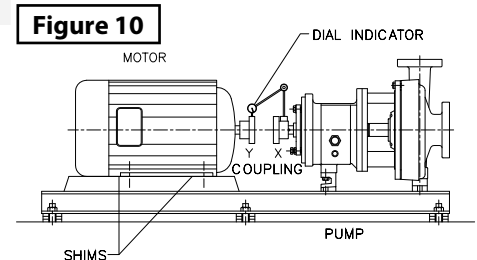

Figure 10

Horizontal: Consist of installing a dial indicator (see Figure 11) in the top half of the coupling "X", leaving it fixed, and then proceeds to inspect the four cardinal points of the "Y" coupling. If readings exceed 0.002" (0.05 mm), means that the motor is offset from the top down, so install or remove equal amounts of shims at the motor feet, to correct the readings.

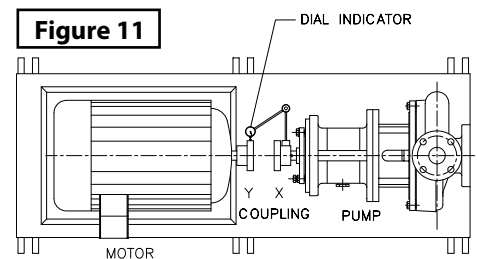

Figure 11

► Concrete pouring application

1. Build a dam with particular area and height for concrete pouring (see Figure 12).
2. Clean the areas that have direct contact with the concrete pouring with a damp cloth, wet thoroughly.
3. It is recommended that pouring be consistent (see distributor instructions).
4. Pour the concrete in order to reach the dam level, then make sure there are no trapped air bubbles.
5. Let first pour harden for 18 hours.
6. Make the second concrete pouring filling the whole base plate (see Figure 13).
7. Let harden the second concrete pouring at least 48 hours.
8. Tighten nuts anchoring the base plate.
9. Verify pump alignment.

Figure 12

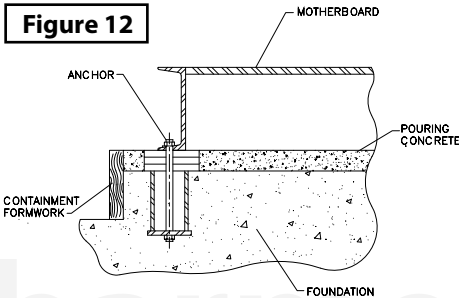
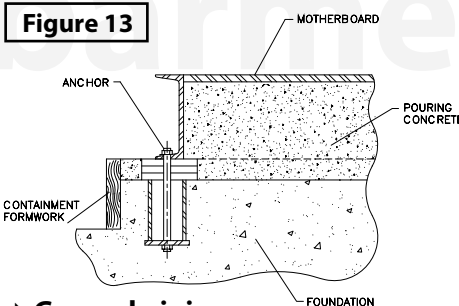

Figure 13



► General piping

1. Clean all pump piping, valves and accessories before assemble.
2. The pipe must be connected to the pump until concrete pouring has completely hardened.
3. The lengths of pipe should be as short as possible in order to minimize friction losses.
4. Where hazardous liquids are handled, piping should allow pump to be washed before disassembling the unit.
5. All piping must be supported independently apart from the pump, this support should be adequate to prevent misalignment of the pump.
6. All the suction pipe must remain adequately submerged below the liquid level avoiding vortex and air pockets in the suction.

Suction pipe

- a) The suction pipe diameter should never be less than the suction flange of the pump, pipe diameter is recommended to be one or two times the suction flange diameter.
- b) In addition, use an eccentric reducer with sloping side down.
- c) Avoid installing short radius elbows.
- d) At least there should be a straight equivalent of 2 or 3 long pipe diameters from the suction flange to the first side section.
- e) When simultaneously having 2 pumps systems working on the same supply the suction pipe must be separated as much as possible.
- f) When the suction is negative, i.e. when the pump is above the suction level (see Figure 18) all joints must be airtight, suction piping must be without air bags, this requires installing a foot valve.
- g) When the suction is positive, i.e. when the pump is with suction flooded, (see Figure 17) a gate valve should be installed in the suction line at least two diameters of the suction flange, no portion of the piping should extend below the suction flange.

Discharge pipe

- a) The discharge must have gate valves and check valves, install the retention valve between the pump and the gate valve, this will permit inspection of the check valve, gate valve is required for the priming, flow regulation, inspection and pump maintenance.
- b) If a reduction bell is used as a booster, it should be placed between the pump and the valve.
- c) Damping devices shall be used to protect pressure pulsations and water hammer.

Final verification

Turn the shaft by hand several times ensure that the parts are friction free, besides verifying alignment in accordance with section "Final alignment".

► Pump start up preparation



CAUTION! - Block the motor power supply before performing any maintenance, operation and repair or adjustment of the pump. (To prevent accidental starting and/or personal injury).

► Pump rotation verification

1. Make sure the coupling is securely fastened to the shaft.
2. Verify that nobody can interfere with this operation.
3. Turn on and off the motor quickly to verify the direction of rotation, rotation should correspond with the shaft on the bearing box. **You may cause severe damage if the pump runs in the wrong direction.**
4. Block the motor power to proceed with the start up preparation.

► Impeller clearance verification

Before operating or starting the pump you should verify the impeller. The efficiency of the pump maintains when having a proper impeller clearance. The best way is obtained by fixing the clear front impeller in the factory, with the default limits that may be compatible with the service conditions. The minimum values for impeller adjustment are illustrated in the "Impellers Clearance at Operating Temperatures" table, where you can find values for different temperatures, depending on the model, these values are necessary to prevent the driver to touch the surface of the body due to dilatation of metal being a result of the pump operation, not being within these ranges may cause significant damage to the unit.

IMPELLER CLEARANCE AT OPERATING TEMPERATURES

OPERATING TEMPERATURE	MODEL 911S	MODEL 911M & 911L	MODEL 911 LX
Up to 93° C (200° F)	0.005" (0.13 mm)	0.008" (0.20 mm)	0.15" (0.38 mm)
93° - 121° C (250° F)	0.007" (0.18 mm)	0.010" (0.26 mm)	0.17" (0.43 mm)
121° - 149° C (300° F)	0.009" (0.23 mm)	0.012" (0.30 mm)	0.19" (0.48 mm)
149° - 177° C (350° F)	0.011" (0.28 mm)	0.014" (0.36 mm)	0.21" (0.53 mm)

► Bearings lubrication

Oil lubrication: Fill the bearing oil by removing the oil filler cap located on top the box until the oil sight glass indicates half, use a high quality oil turbine type with rust and oxidation inhibitors. (See table: "Minimum Requirement for oil lubrication").

Grease: Pumps are shipped grease free. (See Table "Minimum Requirements for grease lubrication").

Bearings greased for life: These bearings are filled with grease and sealed by the manufacturer. If the pump is operated after a long idle time, flush the bearings and bearing frame with a light oil to remove contaminants. During washing, slowly turn the shaft by hand. Finally, flush the bearing box with proper lubricating oil to ensure oil quality after cleaning.

MINIMUM REQUIREMENTS FOR OIL LUBRICATION	
	TEMP. PUMPING UP 177° C (350° F)
ISO DEGREE	VG 68
Approx. SSU - 38° C (100° F)	300
DIN	C68

MINIMUM REQUIREMENTS FOR GREASE LUBRICATION	
	TEMP. PUMPING UP 177° C (350° F)
SKF	LGMT 2
EXXON	UNIREX N2
CONSISTENCY NGLI	2

► Shaft seal

Mechanical seal: the pumps can be sent with or without mechanical seal installed at the factory, the common mechanical seal for BARMESA 911 series pump is the cartridge type; these are prefabricated at the factory and do not require field adjustment, for other types of mechanical seal see the installation instructions and manufacturer setting.

Packing gland: these pumps are shipped without packing rings, lantern rings, gaskets, etc., these are available as accessories and must be installed before starting the pump.

► Packing installation

1. Perfectly clean seal plate cavity.
2. Must twist packing and lantern rings, just to keep in touch with the sleeve, (see in Figures 14 and 15 the correct way to turn these rings is shown).
3. Insert packing, this should be done alternating the joints of each packing and following the sleeve contour.

4. The arrangement of the packaging should be packing rings at the bottom of the chamber, a lantern ring intermediate and three packing rings at the end, then install the gland (see Figure 16, for example).

5. Install the gland by placing the two halves, with studs and install the nuts (hand tightened).

Figure 14

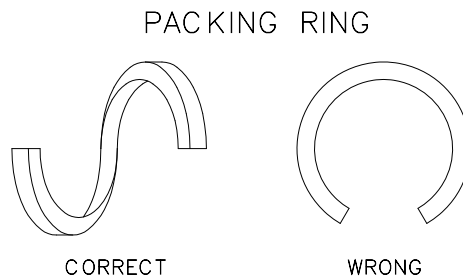

Figure 15

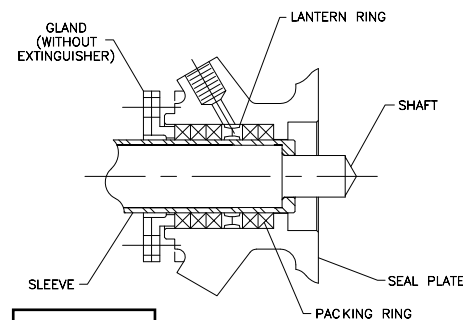
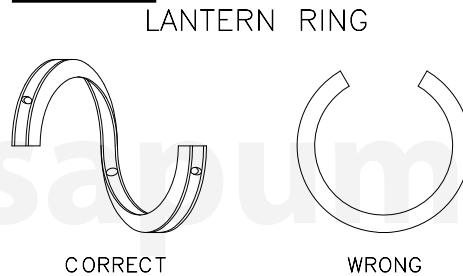

Figure 16

► Priming the pump

Never start the pump until it has been properly primed. You can use different priming methods depending of the type service and installation required.

Providing suctions above the pump:

1. Slowly open the gate valve located in the suction pipe (see Figure 17).
2. Open the vents in the suction and discharge pipe until water flows.
3. Close vent valves.

Providing suctions below the pump:

An aspiration valve and external liquid can be used in order to prime the pump, as shown in Figure 18 and 19. The external liquid can be obtained from a priming pump, a depressurized discharge pipe or an external supply.

1. Close the discharge valve and open the volute vents.
2. Open external supplier valve just enough to have water escape the ventilation valves.
3. Close vent valves first and the external supplier line.

Figure 17

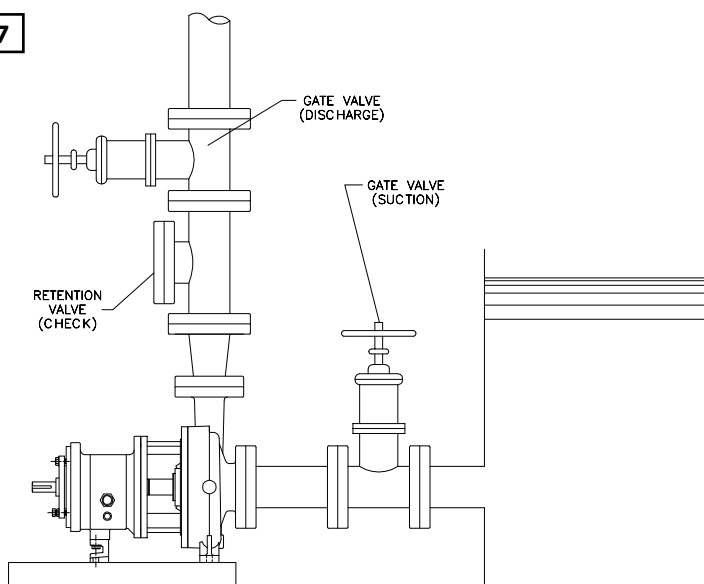

► Pump operation

1. Make sure the suction valve and another recirculation or cooling valves are open.
2. Totally close or partially open the discharge valve, following the system conditions.
3. Start the motor. It is important to observe the manometer. In case the discharge pressure is not reached, stop the engine, prime the pump a second time and start again.
4. Slowly open the discharge valve until the desired flow is obtained.
5. Always operate this pump at or near the flow regime, to prevent damage resulting from cavitations or recirculating conditions.
6. Motor can be overload if the specific gravity (density) of the liquid being pumped is greater than the original stated liquid or if the maximum flow is exceeded. (See table: "Minimum Recommended Flow" for Barmesa 911 series pumps)

Figure 18

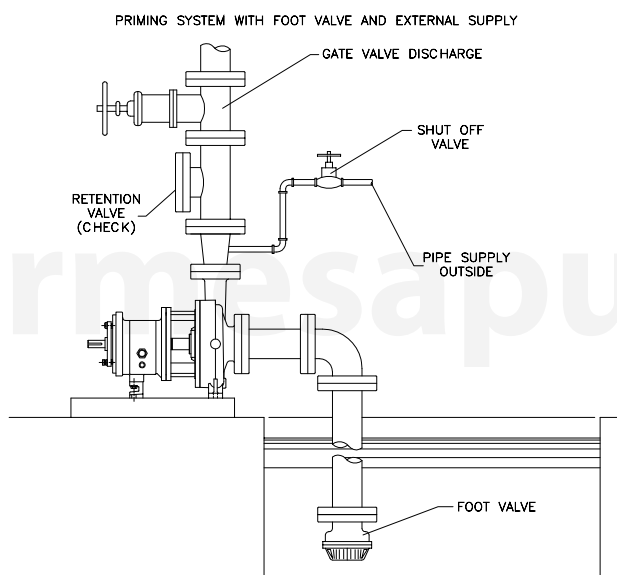

Operating pumps at reduced capacity:

do not operate below the minimum flow requirement or with the discharge/suction valves closed. In this condition there is a risk of an explosion due to the pumping vaporization which may lead to pump a failure or a personal injury.

Operating pumps at freezing conditions:

exposure to freezing conditions while the pump is out of service can cause the liquid to freeze and damage the pump. Liquid should be drained from the pump.

Damages occurring mainly for the following reasons:

1. High radial thrusts (shaft or bearing stresses).
2. High levels of vibration. (Affect bearings, mechanical seal, packing gland).
3. Heat generation. (Vaporization causes inner components to rotate, jam or scratch).
4. Cavitations. (These causes damage within the pump, especially with the pumps impeller).

Figure 19

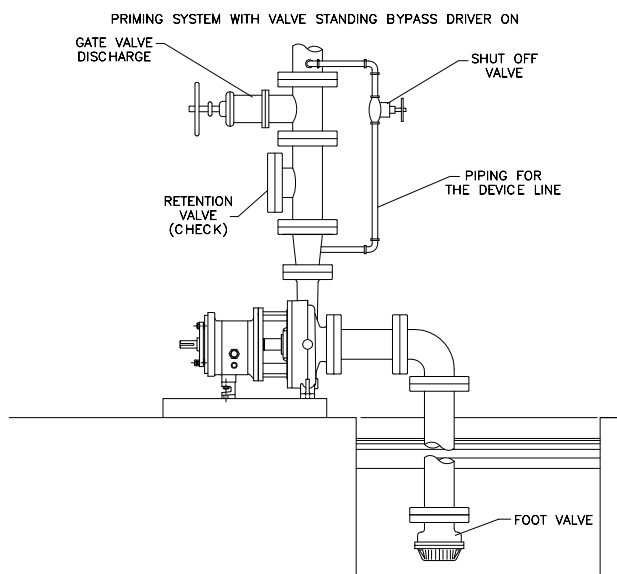

RECOMMENDED MINIMUM FLOW (gallon per minute at the maximum diameter)

SIZE	MODEL	2 POLES / 60 Hz	2 POLES / 50 Hz	4 POLES / 60 Hz	4 POLES / 50 Hz	6 POLES / 60 Hz	6 POLES / 50 Hz
		3560 RPM	2900 RPM	1780 RPM	1470 RPM	1180 RPM	960 RPM
1 x 1½ - 6	911S	10.04	5.02	2.9	1.05	-	-
1½ x 3 - 6		20.08	8.9	5.02	2.11	-	-
2 x 3 - 6		39.89	25.88	8.9	2.9	-	-
1 x 1½ - 8		20.08	12.9	5.02	2.11	-	-
1½ x 3 - 8		39.89	22.98	6.07	2.11	-	-
3 x 4 - 7	911M & 911L	124.95	76.87	12.9	3.96	-	-
2 x 3 - 8		59.96	34.87	8.9	3.96	-	-
3 x 4 - 8		N/A	180.95	100.1	30.9	16.9	-
3 x 4 - 8 G		189.93	104.08	25.88	11.09	-	-
1 x 2 - 10		39.89	21.92	5.02	2.9	2.9	-
1½ x 3 - 10		80.05	56.0	14.0	6.07	5.02	-
2 x 3 - 10		199.98	72.91	19.02	6.07	2.9	-
3 x 4 - 10		199.98	180.95	49.92	20.07	11.88	-
3 x 4 - 10 H		N/A	N/A	150.04	76.08	30.11	11.09
4 x 6 - 10		N/A	N/A	449.88	117.02	78.98	24.03
4 x 6 - 10 H		N/A	N/A	399.95	152.95	85.06	45.96
1½ x 3 - 13		179.9	105.93	44.9	22.98	11.09	-
2 x 3 - 13		239.86	170.91	62.87	36.98	17.96	-
3 x 4 - 13		399.95	332.85	168.01	104.08	67.09	30.9
4 x 6 - 13		N/A	N/A	369.84	296.92	150.04	89.02
6 x 8 - 13		N/A	N/A	849.84	480.0	374.86	197.07
8 x 10 - 13		N/A	N/A	1199.86	974.79	569.81	383.04
6 x 8 - 15		N/A	N/A	999.89	725.94	462.03	276.85
8 x 10 - 15		N/A	N/A	N/A	1399.84	999.89	769.79
8 x 10 - 15 G		N/A	N/A	1399.84	1374.75	846.93	603.89

► Final alignment

1. Start the unit in real operating conditions enough time in order to bring the pump and engine into their operation temperature.
2. Verify alignment while the unit is still hot.
3. Reinstall the coupling guard.

► Routine inspection

- Y Periodically inspect the pump and pipelines, making sure there are no leakage.
- Y Verify unusual sounds, vibrations or temperature on the bearings.
- Y Bearings constantly and periodically lubricated.
- Y Seal inspection (no leakage).
- Y Verify discharge and suction.
- Y Vibrations analysis.
- Y Temperature verification.
- Y Verify oil levels on bearings box.
- Y Packaging (any excessive leak requires adjustments or a possible replacement).

► Bimonthly inspection

- Y Foundation, anchor and hardware inspection verifying everything is well adjust.
- Y Oil change, every two months (1850 hours) or before, depending on conditions where oil can be contaminated or decompose.
- Y If the unit was idle, the packaging should be inspected and if needed replaced.
- Y Bearing periodically inspected and lubricated.

► Yearly inspection

Verify pump capacity, (pressure and power) if the pump efficiency doesn't meet the needed requirements for the process, the pump should be disassembled, inspected and replaced any worn out pieces. In case this inspection results are OK, a system inspection should be done.

► Oil lubricated bearings

To fill the bearing box with oil, first oil cap located on top of the bearing is removed, add oil until the oil sight glass mark is located at the center, then install the oil cap.

OIL VOLUMES		
BEARINGS BOX	PINTS	INCHES
911S	1	15.74
911M	2.6	49.21
911L	3	55.11
911LX	6	118.11

You should change the oil every 1850 hours or every two months, we recommend using high quality oil for most operating conditions such as:

BRAND	DESIGNATION
ROYAL PURPURLE	SYNFILM ISO VG68 SYNTHETIC LUBE
MOBIL	MOBIL DTE 26 300 SSU @ 100° F (38° C)
EXXON	TERESTIC EP 68
SUNOCO	SUNVIS 968

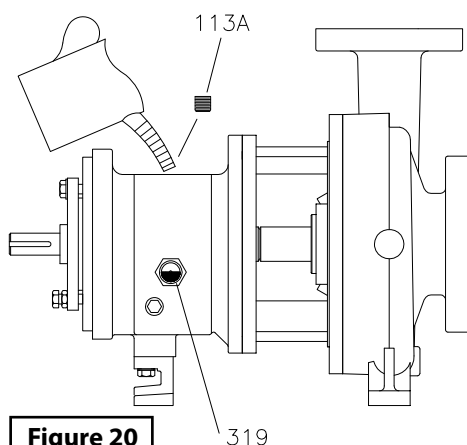

Figure 20

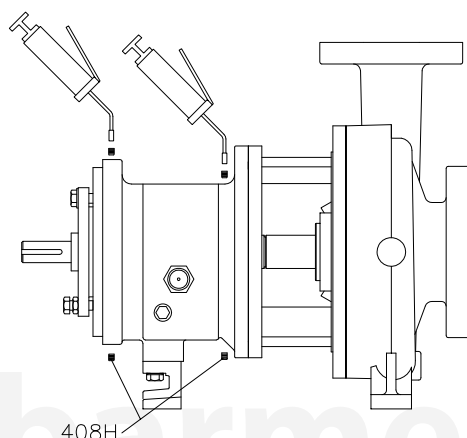

Figure 21

► **Grease lubricated bearings**

1. Clean and wipe out all elements such as: the grease container, relief plugs, etc. to prevent dirt from entering the bearing support.
2. Fill both grease cavities through the greased ducts until fresh grease comes out the relief holes.
3. Reinstall relief plugs in place.

► **Gaskets**

The area used for gaskets and packing glands is not always filled at the factory and must be filled before operating the pump, it can be provided in a box of accessories with the pump. Before installation make sure the gland is clean, check the sleeve for scratches or wear, if so replace if necessary. Begin by placing two packing rings, then the lantern ring, three packing rings, finally adapt the gland (see figure 22). To place the packing and lantern rings you must make a twist motion type, as shown in figure 14 and 15 alternating 90° and tightening each ring to ensure proper compression of the gland.

The gland should be tightened evenly to achieve a good seal, excessive tightening of the gland can cause premature wear on the packaging and/or sleeve. Upon completion of this process, the shaft should be turned by hand once the pump is working a final gland adjustment can be made.

Figure 22

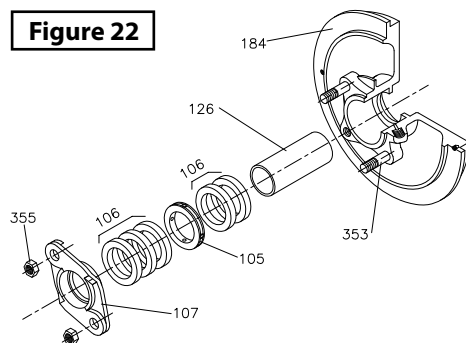

► **Mechanical seal**

If a mechanical seal is required a manufacturer catalog must be provided with its respective data. This catalog or plan shall be kept for future repairs or maintenance. It must also specify the required type of washing liquid and coupling points, every detail of installation, lubrication, pipes must be checked before starting the equipment (see Figure 23).

Because the mechanical seal service life depends on many factors such as: lubrication, maintenance, liquid being handled, operating conditions, etc is not possible to determine the lifetime of the mechanical seal.

Figure 23

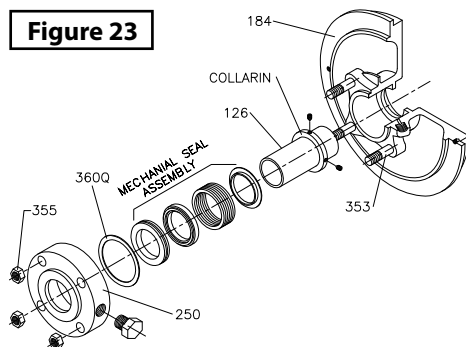

IMPORTANT! - Never operate the pump when fluid is not supplied to the mechanical seal, this can cause damage to the mechanical seal, wearing on sleeve, besides being able to cause serious injury if these seals fail.

► **Impeller clearings adjustment**

As time passes by a change may be noticed in pump performance, this decrease in the work load can be renewed by adjusting the impeller. Here are two techniques explained to perform this procedure.

Feeler gauge method

1. Remove guard.
2. Loosen the leveling screw nut, back screw two or three turns.
3. Tighten evenly each of the screws, then push the bearing supports into the bearing box when the impeller makes contact with the volute, rotate the shaft to ensure uniform contact is made.
4. With a feeler gauge the distance between the three screws, they push the bearing supports should be fixed according to the table: "Impellers clearance at operating temperature".
5. Tighten the leveling screws moving away the bearing support until it makes even contact with fasteners. (See Figure 24).
6. Tighten the locknuts.
7. The shaft should turn freely.
8. Install the coupling guard.

Figure 24

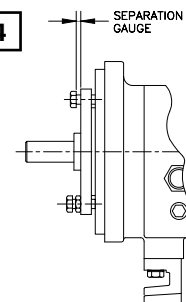

Dial indicator method

1. Remove guard and coupling.
2. The dial indicator is set at the end of the shaft, the gauge sensor must make contact with the shaft's flat face (see Figure 25).

3. Loosen the leveling screw nut, back screw two or three turns.
4. Evenly tighten each of the screws, pushing the bearing support into the bearing box, when the impeller makes contact with the volute, rotate the shaft to ensure uniform contact is made.
5. Gauge is set to zero, and the screws are loosen about one turn.
6. Turn the leveling screws until they make even contact with the bearing.
7. Tighten evenly the leveling screws removing the bearing support of the bearing box until the dial indicator marks the distance or the impeller clearances are appropriate according to the table "Impellers clearance for operating temperatures".
8. Tighten the screws keeping the indicator reading at the proper setting.
9. Tighten the locknuts.
10. The shaft should turn freely.
11. Place coupling in position.
12. Install the coupling guard.

Figure 25

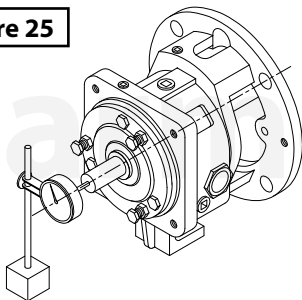

► Pump disassemble

Main precautions

- Before starting the disassembly or performing any work on the pump:
- Y Power energy must be blocked or disconnected in order to avoid an accidental pump start up.
 - Y Use personal protective equipment when performing any maneuver on this pump.
 - Y This pump can handle dangerous and/or toxic liquids, you should never apply heat to remove the components of this pump also at all times you must use personal protective equipment to avoid injury.
 - Y Some elements of this pump are stiff or heavy, extreme precaution is recommended when moving and lifting these parts, all lifting equipment should be resistant, lifting maneuvers and the moving of parts must be correct and careful.

- Y Use heavy duty glove, impeller has sharp edges that removing or installing it could cause injuries.
- Y Before starting any work on the pump you must close all valves and liquid connections, such as suction discharge, auxiliary piping, etc. Once the valves closed, the pump must be drained and washed if necessary.
- Y Make sure you have all the parts, spare parts and tools needed before disassembling the pump.

► Recommended spare parts

- Y Impeler.
- Y Sleeve.
- Y Shaft/coupling.
- Y Outer bearing.
- Y Inner bearing.
- Y Inner labyrinth seal.
- Y Outer labyrinth seal.
- Y Fastening nut.
- Y Lock washer.
- Y Volute gasket.
- Y "O" gasket bearing support.
- Y Bearing box adaptor gasket.
- Y Gland gasket.
- Y "O" impeller's gasket.

► Tools required

- Y Wrench 7/16", 1/2", 9/16", 3/4", 7/8" and 15/16".
- Y Clamps for interior locks.
- Y Pressure clamps.
- Y Soft hammer.
- Y Set of allen keys.
- Y Indoors and outdoors micrometer.
- Y Torque wrenches.
- Y Dial indicator.
- Y Wrench (SKF designations HN6, HN9, HN10).
- Y Adjustable wrench.
- Y Heavy duty gloves.
- Y Cleaning elements.

► Disassembly

1. Close and fully drain the pump and piping, drain the volute and disconnect all auxiliary piping before starting.
2. Remove the coupling guard.
3. Disconnet the coupling.
4. If using oil as a lubricant it should be drained by removing the plug from the bearing box and reinstalling the plug immediately.
5. Volute and the bearing box support screws are removed.

6. Attach the pump with a sling, make sure it is securely fastened to proceed to move it to work place.
7. Move the bearing support to a work place.
8. Remove the shaft's coupling.
9. Remove the impeller, the impeller is remove from the shaft, install a wrench at the end, rotate the impeller clockwise when viewed from the end of the impeller and make sure the wrench handle makes contact with the workbench, quickly rotate the impeller counter clockwise until is loosen.
10. Remove the "O" teflon gasket.
11. Remove the volute gasket, this should be discarded and replaced with a new gasket during reassembly.
12. Remove the leveling screws from the volute adapter.
13. Remove the packing system, either mechanical seal or gland.
14. Remove the seal plate by loosening the nuts in the set crew, then seal plate is removed as well as the packing or mechanical seal.
15. Shaft's sleeve is removed.
16. Loosen screws in bearing box.
17. Bearing box adapter is removed.
18. Remove and discard the adapter's gasket, replacing it with a new one during reassembly.
- 19.- Remove the inner labyrinth seal, located on the bearing box for model 911S and in the adapter for 911L and 911M models, this piece is part of the spare part kits.
- 20.- Once removed the inner labyrinth seal, remove the bearing support, back the lock nuts, tightening evenly the leveling screws to detach the bearing support.
- 21.- Remove all leveling/fastening screws, and locking nuts from the bearing support, store them and inspect them for reassembly, if necessary replace them with new ones.
- 22.- Remove the shaft and rotating elements inside the bearing box.
- 23.- Once out of the bearing box, remove the inner bearing.
- 24.- Remove gasket "O" from the bearing support.
- 25.- For the model 911L, loosen the screws holding the fastening ring and remove the fastening ring bearing. For the 911M and 911S models, remove the lock using tongs for interior locks.

- 26.- Remove labyrinth seal installed on the bearing support.
- 27.- Remove the bearing box, shaft with bearings, lock nut and washer installed.
- 28.- Remove the lock nut, using the respective wrench.
- 29.- Remove the washer.
- 30.- Remove the bearings.
- 31.- Finally the bearing box disassembly, remove all plugs (oil filler, oil drain, oil mist connection, both input and output plugs for oil cooler), plus the oil sight glass and the two guide pins.

Completing this process of dismantling the pump, all parts will be available to proceed to inspection.

▶ Inspections of pump parts

Must inspect all parts of the pump before being reassembled, using the following criteria noted here to achieve a suitable pump operation.

During inspection if any piece or component does not have the minimum requirements it should be replaced.

Impeller: (see Figure 26)

- ÿ You should inspect the impeller vanes checking if they are damaged, must be replaced if the slots are greater than 1/16" deep or if they have a uniform wear over 1/32" (point A).
- ÿ Inspect the rear vanes, if they have more wear than 1/32" (point B), replace the impeller.
- ÿ Inspect the leading and trailing edges of the blades, if these presents corrosion or wear (point C), substitute for a new impeller.

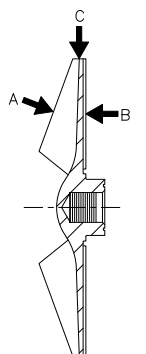

Figure 26

Volute:

- ÿ You should inspect the inside of the body and the gasket body surface, if you have slots than 1/8" it should be repaired or replaced (see Figure 27).

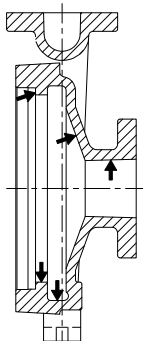

Figure 27

Adapter:

- ÿ When inspecting the adapter, you should check for any cracks or excessive corrosion damage, must be replaced (see Figure 28).

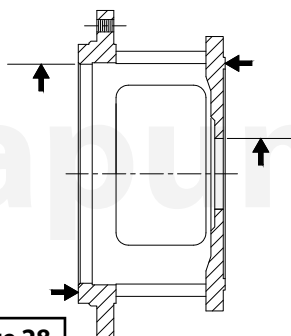
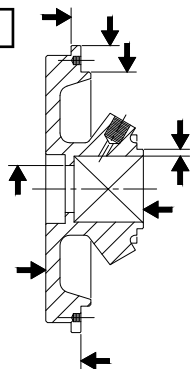

Figure 28

Seal plate:

- ÿ When inspecting the seal plate should check the packing chamber is cleaned and does not have excessive corrosion, in addition review the area of the flat place that makes direct contact with the volute's inside should be replaced if you have any crack or more wear than 1/8" deep (see Figure 29).

Figure 29



Bearing support:

- ÿ Check the bearing seat according to the "Table for bearing adjustment and tolerances", replace if values exceed those listed in the table (see Figure 30).
- ÿ Inspect the lock slot, it should not have any cracks, replace if necessary.

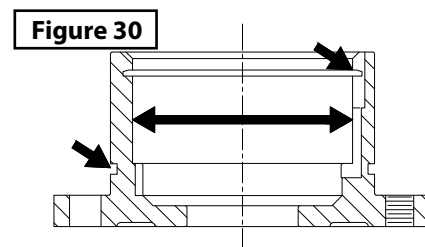

Figure 30

Shaft:

- ÿ Review the shaft, reviewing courts bearings, the setting must match the tolerances specified in the table: "Table for bearing adjustment and tolerances".
- ÿ Inspect the righteousness of the shaft, replace the shaft it exceeds more than 0.002" (0.050 mm) between centers.
- ÿ Inspect the shaft, reviewing the general aspects, replace if you have grooves or pits (see Figure 31).

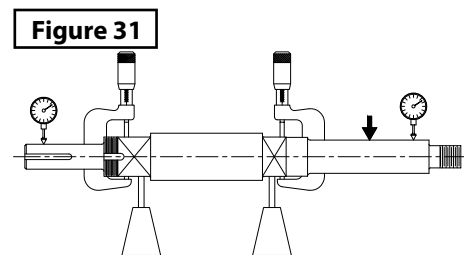

Figure 31

Sleeve:

- ÿ When inspecting the sleeve, review the outer and inner tracks, replace if you have grooves or pits (see Figure 32).

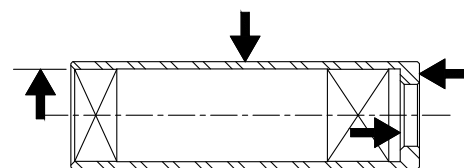

Figure 32

Bearing box and bearing box support:

- Y Inspect the bearing box, make sure it is not cracked.
- Y Inspect the inner bearing according to the "Bearing adjustment and tolerances table"
- Y Replaces if values exceed those listed in this table.
- Y Check all lubrication passages and make sure they are not clogged (see Figure 33).
- Y If the bearing was exposed to the fluid pump, inspect for corrosion, replace if necessary.

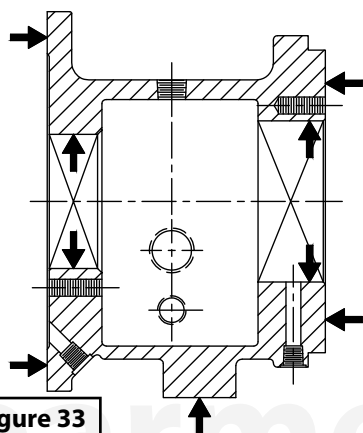

Figure 33

Bearings:

- Y Check the bearings, the condition of these is important in determining working conditions within the bearing box, note the condition of the lubricant, this information may be useful in determining future prevention.
- Y If the wear cause is not normal, it must be corrected before installing new bearings.
- Y Do not reuse the bearings.

Labyrinth seals:

- Y Check the status of the labyrinth seals, inspect so the gaskets have no cuts or cracks, replace if necessary.

BEARINGS TYPE		
Bearing box	Inner bearing	Outer bearing
911S	6207	5306 A/C3
911M	6309	5309 A/C3
911L	6311	7310 BE (DOUBLE)
911LX	6313	5313 A/C3

TABLE SETTINGS AND TOLERANCES BEARINGS

	MODEL 911S	MODEL 911M	MODEL 911L	MODEL 911LX
Outside diameter of the arrow	1.3785	1.7722	2.166	2.5597
	1.2781	1.7718	2.1655	2.5592
	0.0010 tight	0.0010 tight	0.0012 tight	0.0012 tight
	0.0001 tight	0.0001 tight	0.0001 tight	0.0001 tight
Inner diameter of the bearing (int. bearing)	1.378	1.7717	2.1654	2.5591
	1.3775	1.7712	2.1648	2.5585
Housing diameter (int. bearing)	2.8346	3.937	4.7244	5.5118
	2.8353	3.9379	4.7253	5.5128
	0.0012 loose	0.0015 loose	-	0.0017 loose
	0.0000 loose	0.0000 loose	-	0.0000 loose
Outside diameter of the bearing (int. bearing)	2.8346	3.937	4.7244	5.5118
	2.8341	3.9364	4.7238	5.5111
	1.1815	1.7722	1.969	2.5597
Outside diameter of the arrow (ext. bearing)	1.1812	1.7718	1.9686	2.5592
	0.0008 tight	0.0010 tight	-	0.0012 tight
Inner diameter of the bearing (ext. bearing)	0.0001 tight	0.0001 tight	-	0.0001 tight
	1.1811	1.7717	1.9685	2.5591
Housing diameter (ext. bearing)	1.1807	1.7712	1.968	2.5585
	2.8346	3.397	4.3307	5.5118
	2.8353	3.3979	4.3316	5.5128
	0.0012 loose	0.0015 loose	-	0.0017 loose
Outside diameter of the bearing	0.0000 loose	0.0000 loose	-	0.0000 loose
	2.8346	3.937	4.3307	5.5118
Outside diameter of the bearing	2.8341	3.9364	4.3301	5.5111

► Pump reassembly

Before reassembly of the pump, check the threads of all parts of the pump and make sure they are clean and in good condition, otherwise you must inspect them before starting.

► Bearing box assembly

- 1.- Install in the bearing box all screw plugs (the oil drain plug, the four connection plugs oil mist, the two inlet plugs, cooling system outlet plug), in addition to the oil inspection glass and the two guide pins. (See Figure 34)
- 2.- Reinstall the bracket bearing box with screws and washers, hand tight.

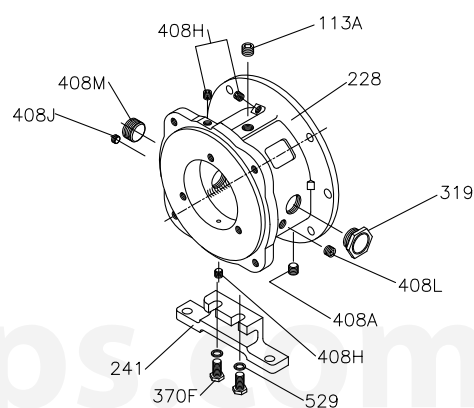

Figure 34

► Mounting the coupling and rotating elements

- 1.- For the 911S and 911M models: Install the outer bearing on the shaft, before installing moisten the inner ring of the bearing with the same oil use during the pump operation. For installation, this bearing has one defense oriented impeller. For the 911L model: Install the outer bearing on the shaft, before installing, make sure your setup in on "O" (back to back, see SKF catalog for more information on this installation), moisten the inside track bearings with the same oil intended for use during pump operation.
- 2.- Place the washer on the shaft, locating tab washer in accordance with the shaft's keyway.
- 3.- Screw the nut fixation on the shaft, once reached the top; help yourself with the respective spanner wrench for proper fit, then twist a washer in one of the nut notches in the corresponding fixation.

4.- For 911S and 911M models: Place the lock through the end of the impeller towards the outside bearing, this lock is beveled at its outer diameter, you must position the flat side toward the outer bearing (see Figure 35).

For the 911L model: Place the retaining bearing ring checking side orientation embedded in the bearing support, this ring will remain loose for a few moments while the inner bearing is installed.

5.- Install the inner bearing on the shaft, before installing brush the bearing inner track with the same oil intended to be used during pump operation.

6.- Install a gasket type "O" on the bearing support in the outer track sealing within the bearing box.

7.- Brush the outer track of the bearing and the inner track of the bearing bracket with the same oil intended to be used during pump operation.

8.- Install the bearing bracket in the shaft with its rotating parts.

9.- For 911S and 911M models: Secure the lock into its slot with tweezers for interior locks, ensure that the oil return slot in the bracket bearing remains unobstructed by the padlock.

For the 911L model: Snap the retaining ring into the bearing box, ensuring that lubrication grooves and screws match with the support, tighten the screws with their respective wrench (see Figure 36).

10.- After step 9 is concluded make sure the shaft turns freely.

11.- Before installing the exterior labyrinth seal, make sure the edges of the keyway on the shaft does not have burrs or sharp parts, in order to protect the outer packaging labyrinth seal.

12.- Install the exterior labyrinth seal in the bearing box, this is with an adjustment gasket type "O" slot oil drain must point downwards (see Figure 37).

13.- Moisten the outer track of the bearing box, the inner bearing and inner track of the bearing with the same oil to be used during pump operation, this to facilitate assembly.

14.- Install the shaft in the bearing with its rotating elements assembled, make sure the shaft turns freely.

15.- The orientation of the bearing support in the bearing box, must match the word "TOP" towards the top of the bearing box, put the screws and the

leveling screws, with its respective nut and hand tighten.

16.- Shaft and rotating elements already installed in the bearing, put a dial indicator on the end of the shaft move the shaft forward, then backward, getting the axial reading, if readings are higher than 0.011" (0.28 mm) for the 911S model, or 0.019" (0.49 mm) for 911L and 911M models, disassemble and determine the cause.

17.- Shaft eccentricity verification, install the sleeve and make sure it is properly installed, screw the drive in the shaft, hand tightening.

18.- Adapt a dial indicator, touching the sleeve track and turn the shaft, if the reading is greater than 0.002" (0.05 mm) disassemble and determine the cause.

19.- Unscrew the impeller and remove the sleeve.

20.- Check the squareness of the face frame against shaft.

21.- Adapt a dial indicator on the shaft, touching the flat face of the frame, hand turn the shaft for 360° if the reading is greater than 0.001" (0.025 mm), disassemble and determine the cause.

22.- Install the gasket adapter.

23.- Install the adapter, ensure the correct position of the adapter through the two bolts and screws, tighten the screws with a torque approximately 45 lbf-ft.

24.- Check the axial, perpendicular and eccentric adapter settings with a dial indicator adapted in the shaft, checking 360°, if the readings are greater than 0.005" (0.013 mm), remove the adapter and determine the cause.

25.- Install the labyrinth seal in the bearing box, this is with an adjustment on the gasket type "O", the oil drain slot should face down (see Figure 37).

Completed this procedure, we proceed with the two forms of sealing, which can be mechanical seal or packaging gland.

Figure 35

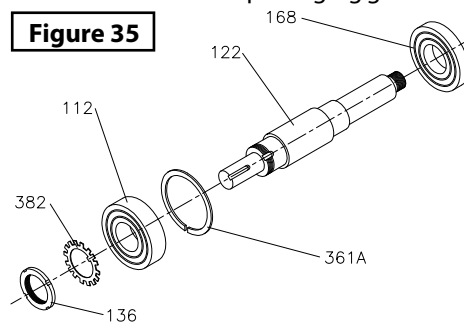

Figure 36

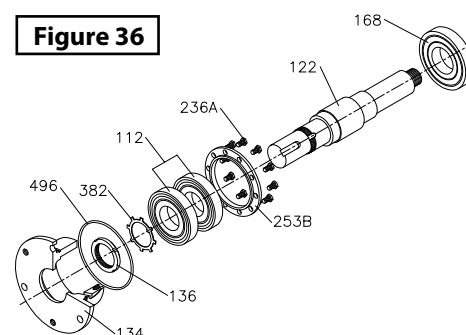
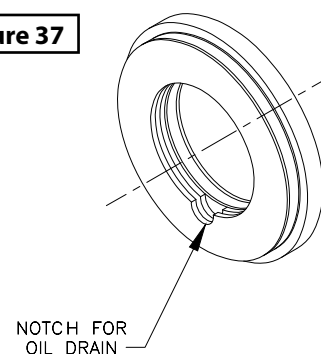

Figure 37



► Pump with mechanical seal

1.- Install the seal plate by holding the adapter, tightening the screws and nuts.

2.- Verify perpendicular and eccentric adjustments on seal plate with a dial indicator adapted on the shaft checking 360° if the readings are higher than 0.005" (0.13 mm), remove the seal plate and determine the cause.

3.- Install the sleeve, ensure sleeve snaps in slot in the bolt hole of the shaft.

4.- Install the impeller with gasket type "O", hand tighten.

5.- Install the keyway in place.

6.- Install a spanner at the end of the shaft, ensure perfectly wedge pinch, rotate the impeller clockwise when viewed from the end of the drive and make sure the handle spanner wrench makes contact with the workbench, quickly turn the impeller clockwise, then tighten the impeller. With a soft hammer lightly tap the drive to achieve proper fit.

7.- At the other end, loosen the screws and leveling of the bearing box support, measure the clearance between the seal plate and impeller with a feeler gauge, when setting clearance to 0.030" (0.76 mm), tighten the screws, leveling and lock nuts, this approximates the impeller position 0.015" (0.38 mm) scroll, final adjustment should be done after installing the volute.

8.- Verify perpendicular and eccentric impeller adjustments, with a dial indicator, checking the 360° between the tips of each blade, if the readings are higher than 0.005" (0.13 mm), remove the impeller and determine the cause.

9.- Mark the sleeve on the outer face, this will serve as a reference when installing the mechanical seal.

10.- Disassembly the impeller and the sleeve.

11.- Remove the seal plate.

12.- Install the mechanical seal according to manufacturer's instructions.

13.- Install the impeller with its new gasket type "O", hand tighten.

14.- Install a spanner at the end of the shaft, ensure perfectly wedge pinch, rotate the impeller clockwise when viewed from the end of the drive and make sure the handle spanner wrench contacts the workbench quickly turn the impeller clockwise, then tighten the impeller, then with a soft hammer lightly tap the drive to achieve proper fit.

15.- Install seal flange with their nuts.

► Pump with gaskets

1.- Install the seal plate grasping it with the adapter, tightening with studs and nuts.

2.- Verify axial, perpendicular and eccentric adjustments on the seal plate with a dial indicator on the shaft, checking 360°, if the readings are higher than 0.005" (0.13 mm), remove the plate seal and determine the cause.

3.- Install the sleeve, make sure the sleeve is properly seated.

4.- Install the impeller with gasket type "O", hand tighten.

5.- Install the keyway in place.

6.- Install a spanner at the end of the shaft, ensure perfectly wedge pinch, rotate the impeller clockwise when viewed from the end of the drive and make sure the handle spanner wrench contacts the workbench, quickly turn the impeller clockwise, then tighten the impeller, then with a soft hammer lightly tap the drive to achieve proper fit.

7.- At the other end loosen the screws and leveling of the bearing box support, measure the clearance between the seal plate and impeller with a feeler gauge, when setting clear to 0.030" (0.76 mm), tighten the screws, leveling and locknuts, this approximates the impeller position

0.015" (0.38 mm) scroll, final adjustment should be done after installing the volute.

8.- Verify perpendicular and eccentric impeller adjustments, with a dial indicator, checking the 360° between the tips of each blade, if the readings are higher than 0.005" (0.13 mm), remove the impeller and determine the cause.

► Pump reinstallation

1.- Install the volute gasket on the seal plate.

2.- Clean adjustment tracks and gasket volute seating.

3.- Loosen the screws and leveling on the bearing box supports.

4.- Install the bearing box.

5.- Install all bolts holding the adapter to the volute, hand tighten, before the final torque, it is recommended to apply the screws an anti-galling compound, to help the disassembly.

6.- Replace shims under bearing box support, adjust a dial indicator to measure the distance between the top of the box and the base plate, it should not vary when the screws are tightened in the bracket to the rack.

7.- Tighten the bolts to 45 lbf-ft.

8.- Install the leveling screws tight fit (do not over tighten).

9.- Verify the total length of the impeller in the volute, this measure should be 0.065" (1.65 mm) with new elements, if not, the elements are inadequate. Determine the cause and correct.

10.- Set the impeller clearance according to section factors.

11.- Fill the bearing box with proper lubricant according to the requirements of the table: "Minimum requirements for lubricating oil".

12.- Finally verified that the impeller can be easily rotated (by hand).

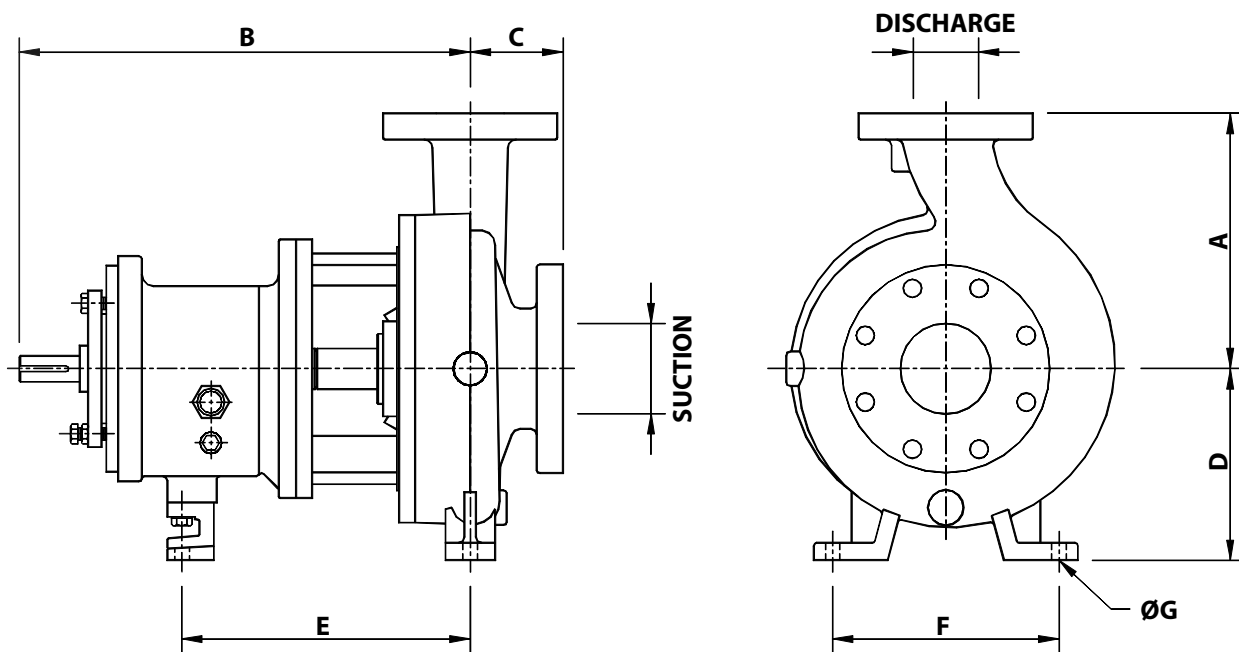

MODEL	PUMP SIZE	ANSI DESIGNATION	DISCHARGE DIAM.	SUCTION DIAM.	A	B	C	D	E	F	ØG HOLES	APROX. WEIGHT (kg)
911S	1 x 1.5 - 6	AA	1	1.5	6.5"	13.5"	4"	5.25"	7.25"	6"	0.625"	38
	1.5 x 3 - 6	AB	1.5	3								42
	2 x 3 - 6	-	2	3								43
	1 x 1.5 - 8	AA	1	1.5							0.563"	45
	1.5 x 3 - 8	AB	1.2	3								49
911M & 911L	3 x 4 - 7	A70	3	4	11"	19.5"	4"	8.25"	12.5"	9.75"	0.625"	100
	2 x 3 - 8	A60	2	3	9.5"							91
	3 x 4 - 8	A70	3	4	11"							100
	3 x 4 - 8G	A70	3	4	11"							100
	1 x 2 - 10	A05	1	2	8.5"			91				
	1.5 x 3 - 10	A50	1.5	3	8.5"			100				
	2 x 3 - 10	A60	2	3	9.5"			104				
	3 x 4 - 10	A70	3	4	11"			120				
	3 x 4 - 10H	A40	3	4	12.5"			138				
	4 x 6 - 10	A80	4	6	13.5"			138				
	4 x 6 - 10H	A80	4	6	13.5"			138				
	1.5 x 3 - 13	A20	1.5	3	10.5"			10"				111
	2 x 3 - 13	A30	2	3	11.5"							125
	3 x 4 - 13	A40	3	4	12.5"						150	
4 x 6 - 13	A80	4	6	13.5"	0.563"	184						
911LX	6 x 8 - 13	A90	6	8	16"	27.9"	6"	14.5"	18.75"	16"	0.875"	254
	8 x 10 - 13	A100	8	10	18"							304
	6 x 8 - 15	A110	6	8	18"							277
	8 x 10 - 15	A120	8	10	19"							336
	8 x 10 - 15G	A120	8	10	19"							710

EXPLODED VIEW DRAWING

Series: 911S

FOR SIZES:
1x1.5-6, 1.5X3-6, 2x3-6.

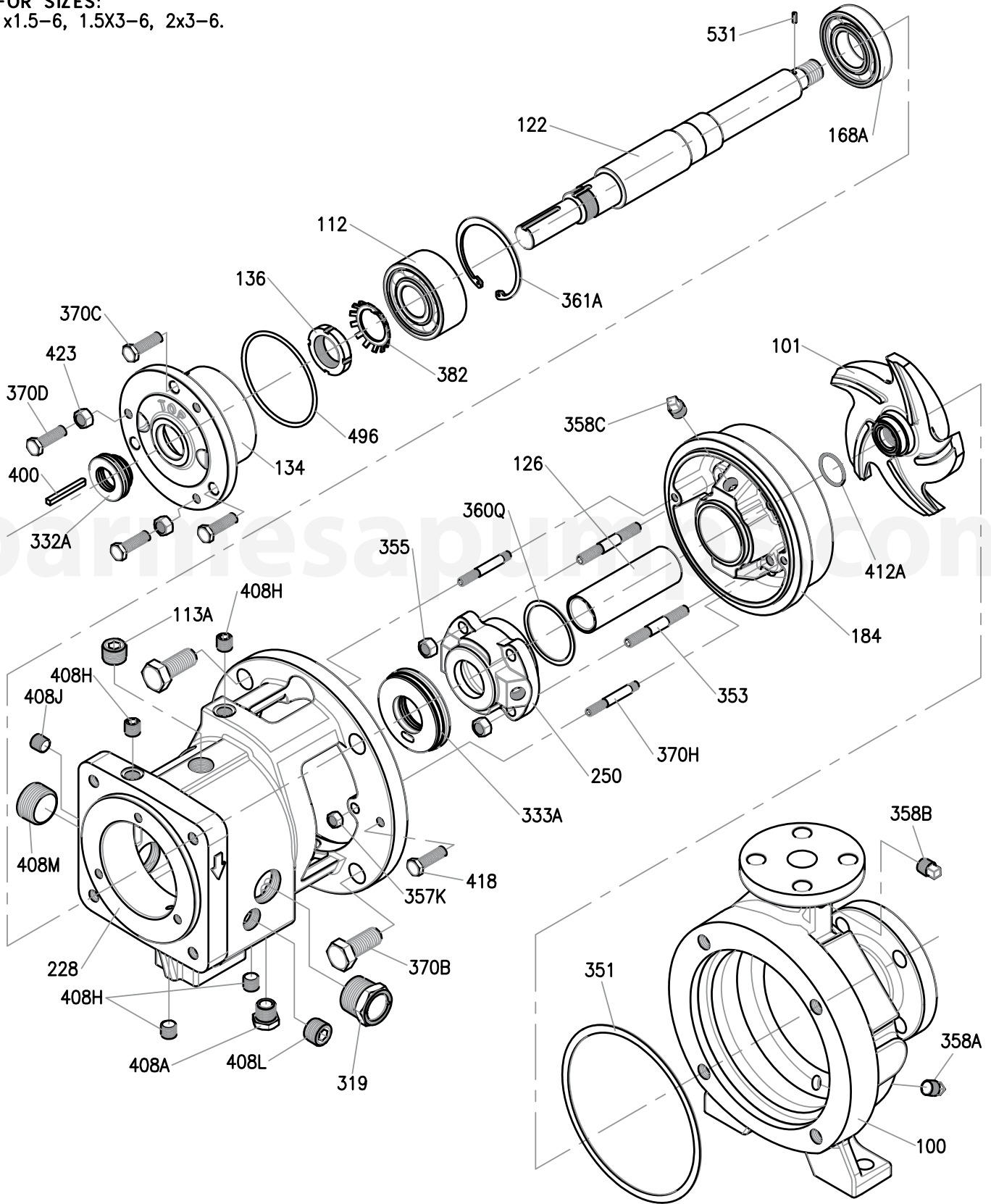

PART LISTSeries: **911S**

ITEM	QTY.	DESCRIPTION	MATERIAL	PART No.
100	1	Casing 1x1.5-6	Cast iron	03730010
			CF8M	03730011
		Casing 1.5x3-6	Cast iron	03730020
			CF8M	03730021
		Casing 2x3-6	Cast iron	03730030
			CF8M	03730031
101	1	Impeller 1x1.5-6	Cast iron	03750010
			CF8M	03750011
		Impeller 1.5x3-6	Cast iron	03750020
			CF8M	03750021
		Impeller 2x3-6	Cast iron	03750030
			CF8M	03750031
105	1	Lantern ring 911 S	Teflon®	31010026
106	5	Cord ring 5/16"	Teflon®	92010135
107	1	Stuffing box 911 S	CF8M	30300203
112	1	Outer bearing	Steel	31020023
113A	1	Dry seal cap ½"	Steel	93010112
122	1	Shaft with sleeve	Steel 4140	30300351
		Shaft without sleeve	316 SS	30300356
126	1	Sleeve	316 SS	30300681
134	1	Bearing support	Cast iron	03780001
136	1	Safety nut M6	Steel	91010451
168A	1	Inner bearing	Steel	31020022
184	1	Seal plate 6"	Cast iron	03770010
			CF8M	03770011
228	1	Frame 911 S	Cast iron	03720001
250	1	Mechanical seal flange	CF8M	30300301
319	1	Oil sight glass	Steel/Glass	31120011
332A	1	Outboard lab'y seal 911 S	Bronze	31030202
333A	1	Inboard lab'y seal 911 S	Bronze	31030201
351	1	Body gasket 6"	EPDM	92010194
353	4	Stud screw 3/8"x 4"	304 SS	91010375
355	4	Nut 3/8"	304 SS	91010433
357K	2	Nut 5/16"	304 SS	91010432
358C	1	Plug ¼"	Steel Galv.	93010143
			304 SS	S/N
360Q	1	Seal flange gasket	EPDM	92010176
361A	1	Snap ring	Steel	31010011
370B	4	Screw 5/8"x 1½"	Carbon Steel	91010282
			304 SS	91010354
370C	3	Screw 3/8"x 1¼"	Carbon Steel	91010243
370D	3	Screw 3/8"x 1¼"	Carbon Steel	91010243
370H	2	Stud screw 5/16" x 1-7/8"	304 SS	91010372B
382	1	Lock washer MB6	Steel	91010058
400	1	Key 3/16"	Steel 1018	30400631
408A	1	Plug 3/8"	Cast iron	93010149
408H	4	Dry seal cap ¼"	Steel	93010113
408J	1	Dry seal cap ¼"	Steel	93010113
408L	1	Dry seal cap ½"	Steel	93010112
408M	1	Dry seal cap 1"	Steel	93010111
412A	1	Impeller gasket	Teflon®	92010059
418	2	Screw 3/8" x 1½"	304 SS	91010346
423	3	Nut 3/8"	Steel	91010413
496	1	Support gasket	Buna-N	92010039
531	1	Roll pin	Steel	91010184

EXPLODED VIEW DRAWING

Series: 911S

FOR SIZES:
1x1.5-8, 1.5x3-8.

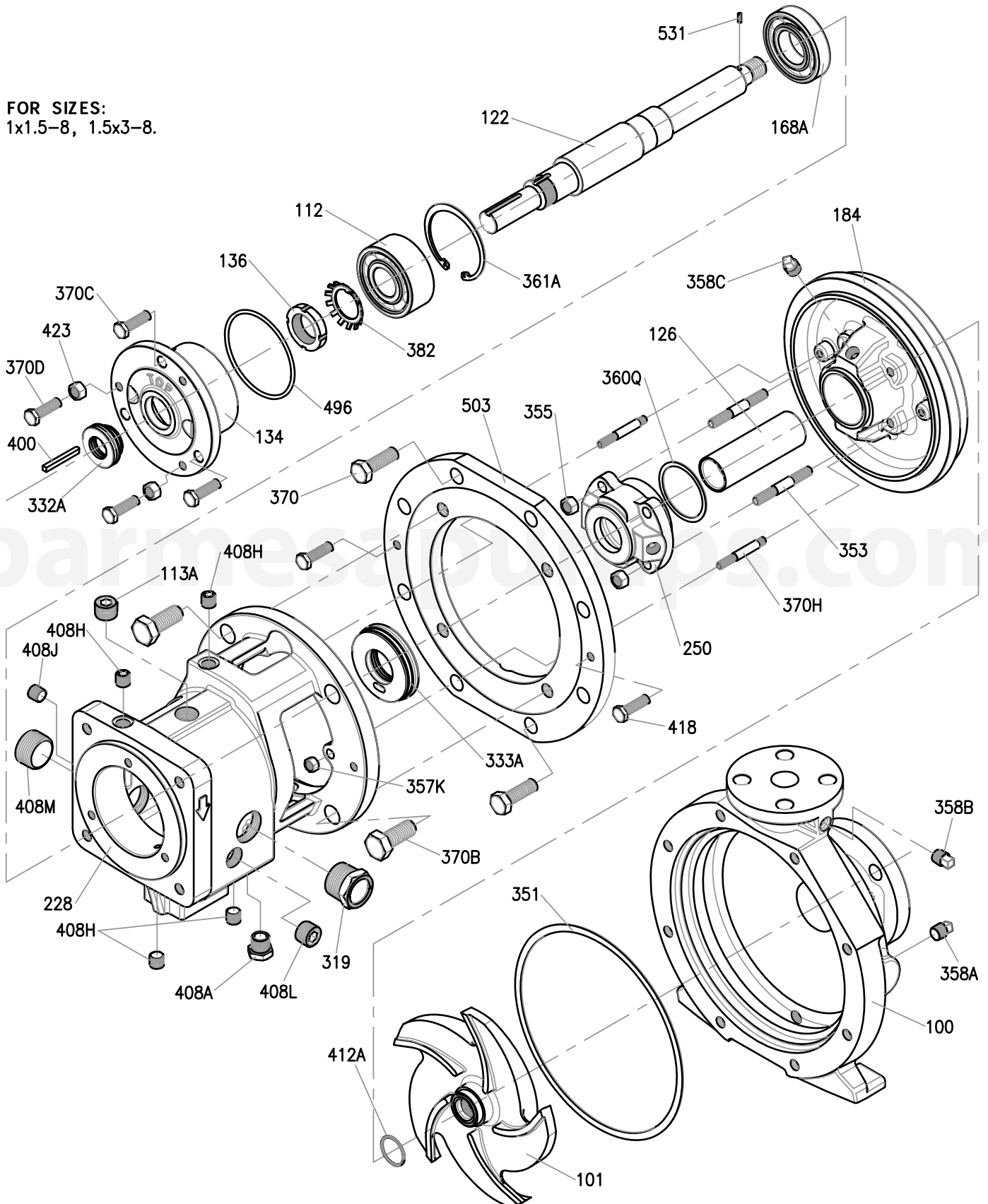

SECTIONAL VIEW DRAWING

Series: 911S

FOR SIZES: 1x1.5-8
& 1.5x3-8

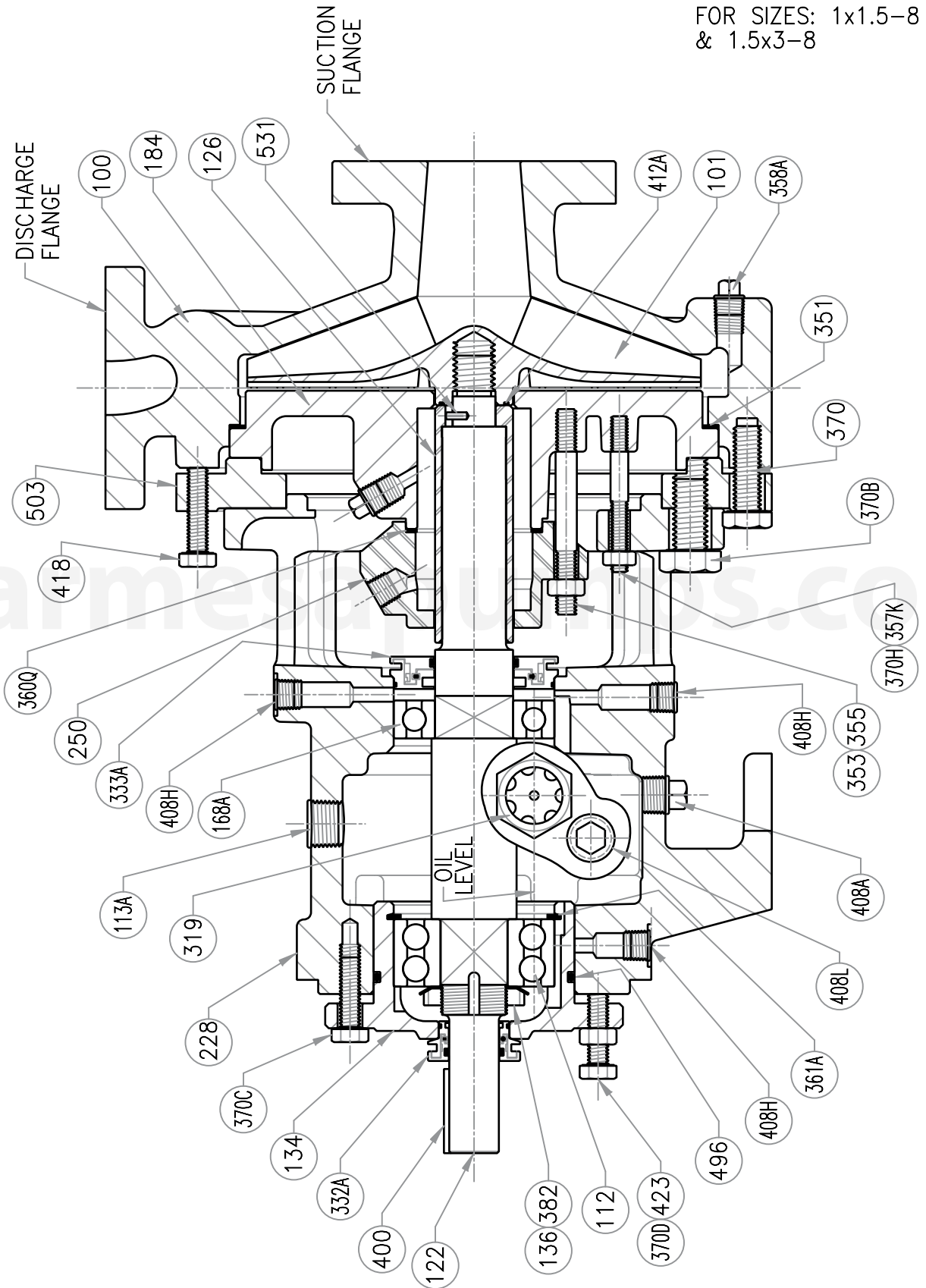

PART LIST

Series: 911S

ITEM	QTY.	DESCRIPTION	MATERIAL	PART No.
100	1	Casing 1x1.5-8	Cast iron	03730040
			CF8M	03730041
		Casing 1.5x3-8	Cast iron	03730050
			CF8M	03730051
101	1	Impeller 1x1.5-8	Cast iron	03750040
			CF8M	03750041
		Impeller 1.5x3-8	Cast iron	03750050
			CF8M	03750051
105	1	Lantern ring 911 S	Teflon®	31010026
106	5	Cord ring 5/16"	Teflon®	92010135
107	1	Stuffing box 911 S	CF8M	30300203
112	1	Outer bearing	Steel	31020023
113A	1	Dry seal cap ½"	Steel	93010112
122	1	Shaft with sleeve	Steel 4140	30300351
		Shaft without sleeve	316 SS	30300356
126	1	Sleeve	316 SS	30300681
134	1	Bearing support	Cast iron	03780001
136	1	Safety nut M6	Steel	91010451
168A	1	Inner bearing	Steel	31020022
184	1	Seal plate 8"	Cast iron	03770020
			CF8M	03770021
228	1	Frame 911 S	Cast iron	03720001
250	1	Mechanical seal flange	CF8M	30300301
319	1	Oil sight glass	Steel/Glass	31120011
332A	1	Outboard lab'y seal 911 S	Bronze	31030202
333A	1	Inboard lab'y seal 911 S	Bronze	31030201
351	1	Body gasket 8"	EPDM	92010195
353	4	Stud screw 3/8"x 4"	304 SS	91010375
355	4	Nut 3/8"	304 SS	91010433
357K	2	Nut 5/16"	304 SS	91010432
358C	1	Plug ¼"	Steel Galv.	93010143
			304 SS	S/N
360Q	1	Seal flange gasket	EPDM	92010176
361A	1	Snap ring	Steel	31010011
370	8	Screw ½"x 1½"	Carbon Steel	91010263
			304 SS	91010351
370B	4	Screw 5/8"x 1¼"	Carbon Steel	91010289
370C	3	Screw 3/8"x 1¼"	Carbon Steel	91010243
370D	3	Screw 3/8"x 1¼"	Carbon Steel	91010243
370H	2	Stud screw 5/16" x 2¾"	304 SS	91010372
382	1	Lock washer MB6	Steel	91010058
400	1	Key 3/16"	Steel 1018	30400631
408A	1	Plug 3/8"	Cast iron	93010149
408H	4	Dry seal cap ¼"	Steel	93010113
408J	1	Dry seal cap ¼"	Steel	93010113
408L	1	Dry seal cap ½"	Steel	93010112
408M	1	Dry seal cap 1"	Steel	93010111
412A	1	Impeller gasket	Teflon®	92010059
418	2	Screw 3/8" x 1½"	304 SS	91010346
423	3	Nut 3/8"	Steel	91010413
496	1	Support gasket	Buna-N	92010039
503	1	Adapter 8" 911S	Cast iron	03710001
531	1	Roll pin	Steel	91010184

EXPLODED VIEW DRAWING

Series: 911M

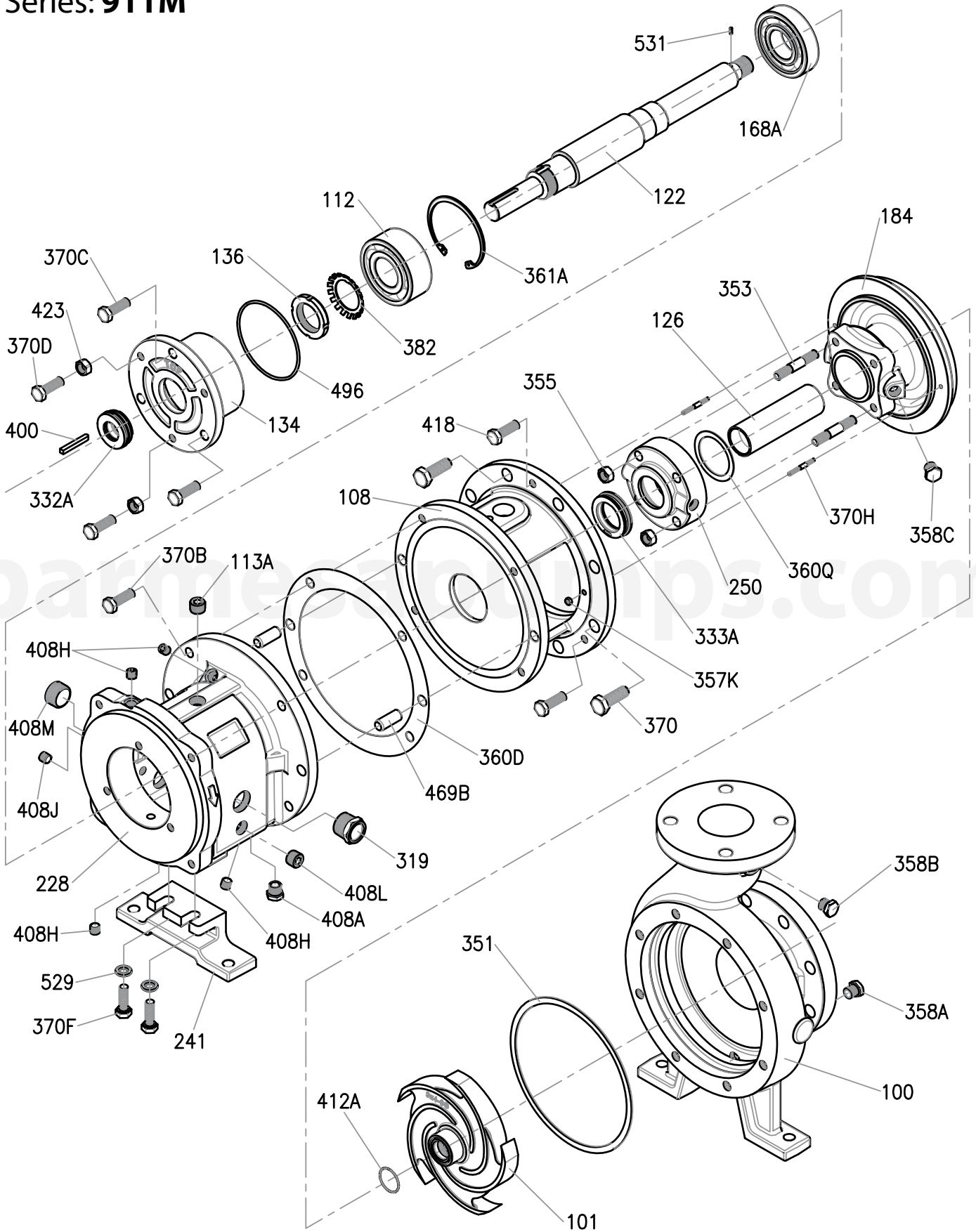

SECTIONAL VIEW DRAWING

Series: 911M

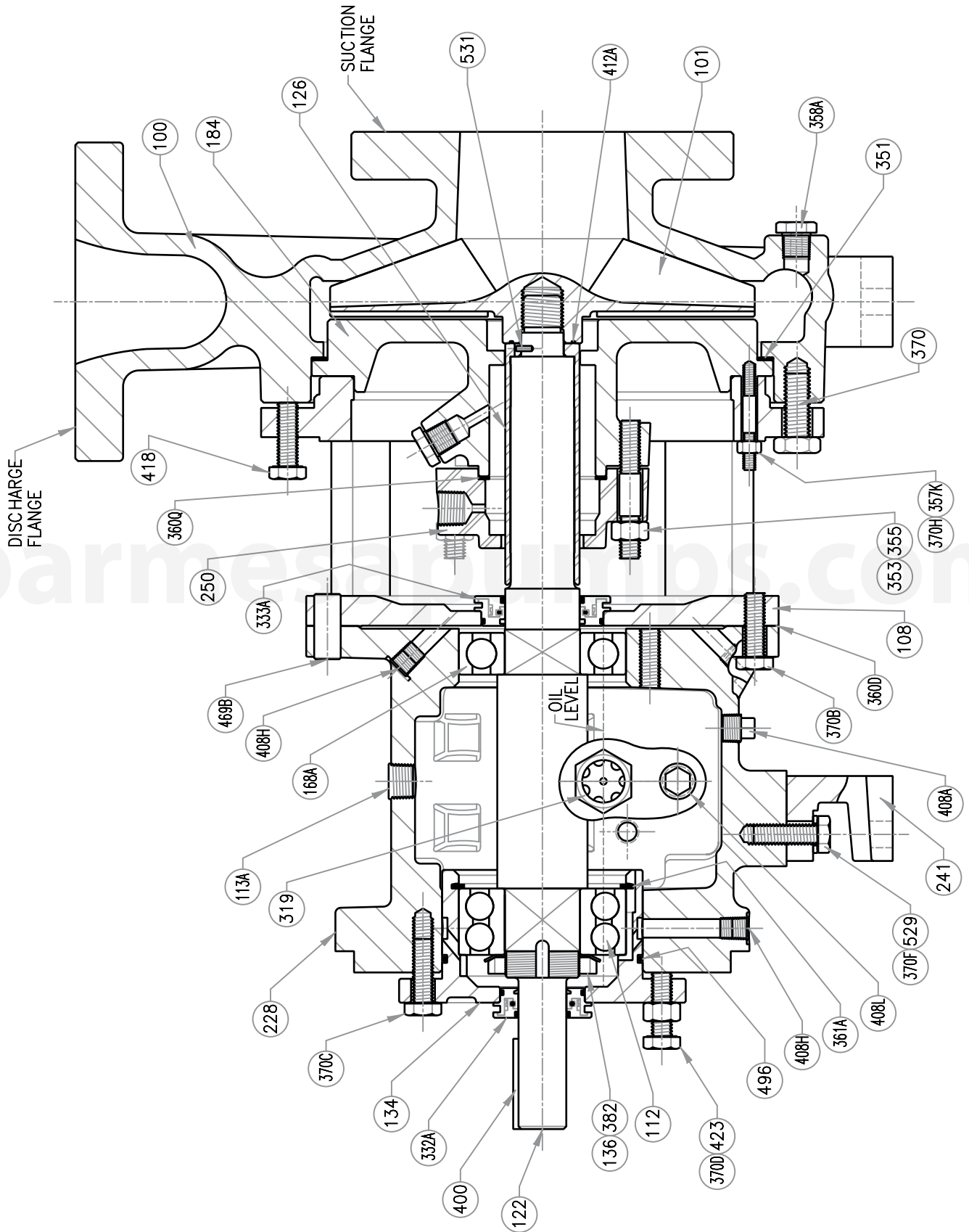

PART LIST

Series: 911M

ITEM	QTY.	DESCRIPTION	MATERIAL	PART No.
100	1	Casing 3x4-7	Cast iron	03730060
			CF8M	03730061
		Casing 2x3-8	Cast iron	03730070
			CF8M	03730071
		Casing 3x4-8	Cast iron	03730080
			CF8M	03730081
		Casing 3x4-8G	Cast iron	03730090
			CF8M	03730091
101	1	Impeller 3x4-7	Cast iron	03750060
			CF8M	03750061
		Impeller 2x3-8	Cast iron	03750070
			CF8M	03750071
		Impeller 3x4-8	Cast iron	03750080
			CF8M	03750081
		Impeller 3x4-8G	Cast iron	03750090
			CF8M	03750091
105	1	Lantern ring 911 M	Teflon®	31010027
106	5	Cord ring 3/8"	Teflon®	92010134
107	1	Stuffing box 911 M	CF8M	30300202
108	1	Adapter 8"	Cast iron	03710002
112	1	Outer bearing	Steel	31020024
113A	1	Dry seal cap 1/2"	Steel	93010112
122	1	Shaft with sleeve	Steel 4140	30300352
		Shaft without sleeve	316 SS	30300360
126	1	Sleeve	316 SS	30300682
134	1	Bearing support	Cast iron	03780002
136	1	Safety nut M9	Steel	91010453
168A	1	Inner bearing	Steel	31020025
184	1	Seal plate 8"	Cast iron	03770030
			CF8M	03770031
228	1	Frame 911 M	Cast iron	03720002
241	1	Frame support 8 1/4"	Cast iron	03790001
250	1	Mechanical seal flange	CF8M	30300302
319	1	Oil sight glass	Steel/Glass	31120011
332A	1	Outboard lab'y seal 911 M	Bronze	31030203
333A	1	Inboard lab'y seal 911 M	Bronze	31030204
351	1	Body gasket 8"	EPDM	92010196
353	4	Stud screw 1/2"x 3/4" lgo.	304 SS	91010378
355	4	Nut 1/2"	304 SS	91010435
357K	2	Nut 3/16"	304 SS	91010431
358C	1	Plug 3/8"	Cast iron	93010149
			304 SS	93010131
360D	1	Adapter gasket	Vellumoid	92010171
360Q	1	Seal flange gasket	EPDM	92010177
361A	1	Snap ring	Steel	31010012
370	8	Screw 5/8"x 1 1/2"	Carbon Steel	91010282
			304 SS	91010354
370B	4	Screw 1/2"x 1 1/2"	Carbon Steel	91010263
370C	3	Screw 1/2"x 1 1/2"	Carbon Steel	91010263
370D	3	Screw 1/2"x 1 1/2"	Carbon Steel	91010263
370F	2	Screw 1/2"x 1 1/2"	Carbon Steel	91010263
370H	2	Stud screw 3/16" x 2 1/2"	304 SS	91010371
382	1	Lock washer MB9	Steel	91010059
400	1	Key 1/4"	Steel 1018	30400633
408A	1	Plug 3/8"	Cast iron	93010149
408H	4	Dry seal cap 1/4"	Steel	93010113
408J	1	Dry seal cap 1/4"	Steel	93010113
408L	1	Dry seal cap 1/2"	Steel	93010112
408M	1	Dry seal cap 1"	Steel	93010111
412A	1	Impeller gasket	Teflon®	92010058
418	3	Screw 1/2"x 1 1/2"	304 SS	91010351
423	3	Nut 1/2"	Steel	91010415
469B	2	Dowel Pin Frame	Steel 1018	30400864
496	1	Support gasket	Buna-N	92010040
529	2	Spring washer	Steel	91010014
531	1	Roll pin	Steel	91010184

ITEM	QTY.	DESCRIPTION	MATERIAL	PART No.
100	1	Casing 1x2-10	Cast iron	03730100
			CF8M	03730101
		Casing 1.5x3-10	Cast iron	03730110
			CF8M	03730111
		Casing 2x3-10	Cast iron	03730120
			CF8M	03730121
		Casing 3x4-10	Cast iron	03730130
			CF8M	03730131
		Casing 3x4-10H	Cast iron	03730140
			CF8M	03730141
		Casing 4x6-10	Cast iron	03730150
			CF8M	03730151
		Casing 4x6-10H	Cast iron	03730160
			CF8M	03730161
101	1	Impeller 1x2-10	Cast iron	03750100
			CF8M	03750101
		Impeller 1.5x3-10	Cast iron	03750110
			CF8M	03750111
		Impeller 2x3-10	Cast iron	03750120
			CF8M	03750121
		Impeller 3x4-10	Cast iron	03750130
			CF8M	03750131
		Impeller 3x4-10H	Cast iron	03750140
			CF8M	03750141
		Impeller 4x6-10	Cast iron	03750150
			CF8M	03750151
		Impeller 4x6-10H	Cast iron	03750160
			CF8M	03750161
105	1	Flashlight ring 911 M	Teflon®	31010027
106	5	Cord ring 3/8"	Teflon®	92010134
107	1	Stuffing box 911 M	CF8M	30300202
108	1	Adapter 10"	Cast iron	03710003
112	1	Outer bearing	Steel	31020024
113A	1	Dry seal cap 1/2"	Steel	93010112
122	1	Shaft with sleeve	Steel 4140	30300352
		Shaft without sleeve	316 SS	30300360
126	1	Sleeve	316 SS	30300682
134	1	Bearing support	Cast iron	03780002
136	1	Safety nut M9	Steel	91010453
168A	1	Inner bearing	Steel	31020025
184	1	Seal plate 10"	Cast iron	03770040
			CF8M	03770041
228	1	Frame 911 M	Cast iron	03720002
241	1	Frame support 8 1/4"	Cast iron	03790001
		Frame support 10"	Cast iron	03790002
250	1	Mechanical seal flange	CF8M	30300302
319	1	Oil sight glass	Steel/Glass	31120011
332A	1	Outboard lab'y seal 911 M	Bronze	31030203
333A	1	Inboard lab'y seal 911 M	Bronze	31030204
351	1	Body gasket 10"	EPDM	92010197
353	4	Stud screw 1/2"x 3/4" lgo.	304 SS	91010378
355	4	Nut 1/2"	304 SS	91010435
357K	2	Nut 5/16"	304 SS	91010432
358C	1	Plug 3/8"	Cast iron	93010149
			304 SS	93010131
360D	1	Adapter gasket	Vellumoid	92010171
360Q	1	Seal flange gasket	EPDM	92010177
361A	1	Snap ring	Steel	31010012
370	12	Screw 5/8"x 1 1/2"	Carbon Steel	91010282
			304 SS	91010354
370B	4	Screw 1/2"x 1 1/2"	Carbon Steel	91010263
370C	3	Screw 1/2"x 1 1/2"	Carbon Steel	91010263
370D	3	Screw 1/2"x 1 1/2"	Carbon Steel	91010263
370F	2	Screw 1/2"x 1 1/2"	Carbon Steel	91010263
370H	2	Stud screw 5/16" x 2 3/4"	304 SS	91010372
382	1	Lock washer MB9	Steel	91010059

ITEM	QTY.	DESCRIPTION	MATERIAL	PART No.
400	1	Key 1/4"	Steel 1018	30400633
408A	1	Plug 3/8"	Cast iron	93010149
408H	4	Dry seal cap 1/4"	Steel	93010113
408J	1	Dry seal cap 1/4"	Steel	93010113
408L	1	Dry seal cap 1/2"	Steel	93010112
408M	1	Dry seal cap 1"	Steel	93010111
412A	1	Impeller gasket	Teflon®	92010058
418	3	Screw 1/2"x 1 1/2"	304 SS	91010351
423	3	Nut 1/2"	Steel	91010415
469B	2	Dowel Pin Frame	Steel 1018	30400864
496	1	Support gasket	Buna-N	92010040
529	2	Spring washer	Steel	91010014
531	1	Roll pin	Steel	91010184

ITEM	QTY.	DESCRIPTION	MATERIAL	PART No.
100	1	Casing 1.5x3-13	Cast iron	03730170
			CF8M	03730171
		Casing 2x3-13	Cast iron	03730180
			CF8M	03730181
		Casing 3x4-13	Cast iron	03730190
			CF8M	03730191
		Casing 4x6-13	Cast iron	03730200
			CF8M	03730201
101	1	Impeller 1.5x3-13	Cast iron	03750170
			CF8M	03750171
		Impeller 2x3-13	Cast iron	03750180
			CF8M	03750181
		Impeller 3x4-13	Cast iron	03750190
			CF8M	03750191
		Impeller 4x6-13	Cast iron	03750200
			CF8M	03750201
105	1	Lantern ring 911 M	Teflon®	31010027
106	5	Cord ring 3/8"	Teflon®	92010134
107	1	Stuffing box 911 M	CF8M	30300202
108	1	Adapter 13"	Cast iron	03710004
112	1	Outer bearing	Steel	31020024
113A	1	Dry seal cap 1/2"	Steel	93010112
122	1	Shaft with sleeve	Steel 4140	30300352
		Shaft without sleeve	316 SS	30300360
126	1	Sleeve	316 SS	30300682
134	1	Bearing support	Cast iron	03780002
136	1	Safety nut M9	Steel	91010453
168A	1	Inner bearing	Steel	31020025
184	1	Seal plate 13"	Cast iron	03770050
			CF8M	03770051
228	1	Frame 911 M	Cast iron	03720002
241	1	Frame support 10"	Cast iron	03790002
250	1	Mechanical seal flange	CF8M	30300302
319	1	Oil sight glass	Steel/Glass	31120011
332A	1	Outboard lab'y seal 911 M	Bronze	31030203
333A	1	Inboard lab'y seal 911 M	Bronze	31030204
351	1	Body gasket 13"	EPDM	92010198
353	4	Stud screw 1/2"x 3/4" lgo.	304 SS	91010378
355	4	Nut 1/2"	304 SS	91010435
357K	2	Nut 5/16"	304 SS	91010432
358C	1	Plug 3/8"	Cast iron	93010149
			304 SS	93010131
360D	1	Adapter gasket	Vellumoid	92010171
360Q	1	Seal flange gasket	EPDM	92010177
361A	1	Snap ring	Steel	31010012
370	16	Screw 5/8"x 1 1/2"	Carbon Steel	91010282
			304 SS	91010354
370B	4	Screw 1/2"x 1 1/2"	Carbon Steel	91010263
370C	3	Screw 1/2"x 1 1/2"	Carbon Steel	91010263
370D	3	Screw 1/2"x 1 1/2"	Carbon Steel	91010263
370F	2	Screw 1/2"x 1 1/2"	Carbon Steel	91010263
370H	2	Stud screw 5/16" x 2 3/4"	304 SS	91010372
382	1	Lock washer MB9	Steel	91010059
400	1	Key de 1/4"	Steel 1018	30400633
408A	1	Plug de 3/8"	Cast iron	93010149
408H	4	Dry seal cap 1/4"	Steel	93010113
408J	1	Dry seal cap 1/4"	Steel	93010113
408L	1	Dry seal cap 1/2"	Steel	93010112
408M	1	Dry seal cap 1"	Steel	93010111
412A	1	Impeller gasket	Teflon®	92010058
418	3	Screw 1/2"x 1 1/2"	304 SS	91010351
423	3	Nut 1/2"	Steel	91010415
469B	2	Dowel Pin Frame	Steel 1018	30400864
496	1	Support gasket	Buna-N	92010040
529	2	Spring washer	Steel	91010014
531	1	Roll pin	Steel	91010184

EXPLODED VIEW DRAWING

Series: **911L**

NOTE:
ITEM 112, THE 911L SIZE USES 2 BEARINGS
SKF #7310 BECBM, MOUNTED BACK TO
BACK. BE SURE THAT THE INSTALLATION IS
CORRECT.

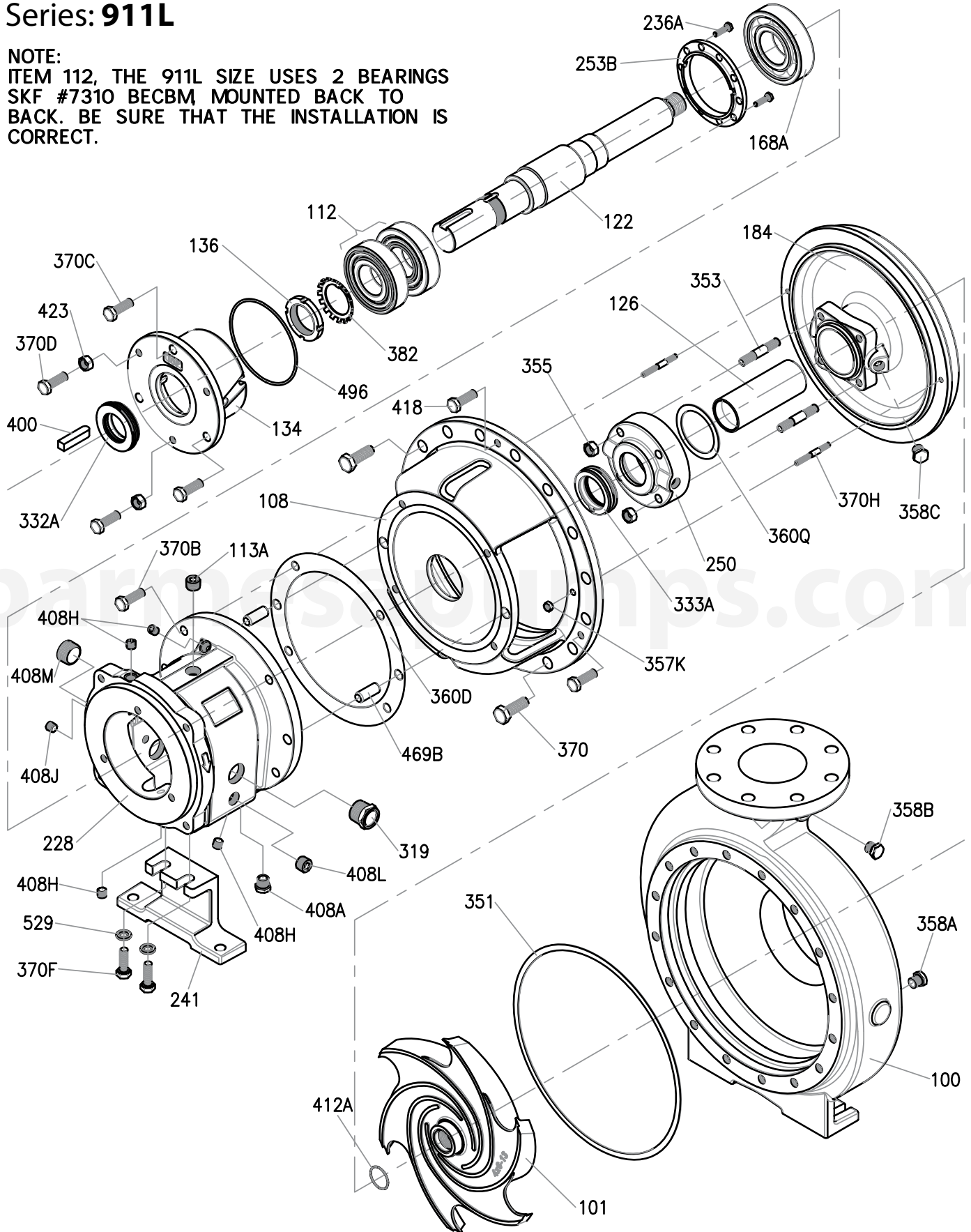

SECTIONAL VIEW DRAWING

Series: 911L

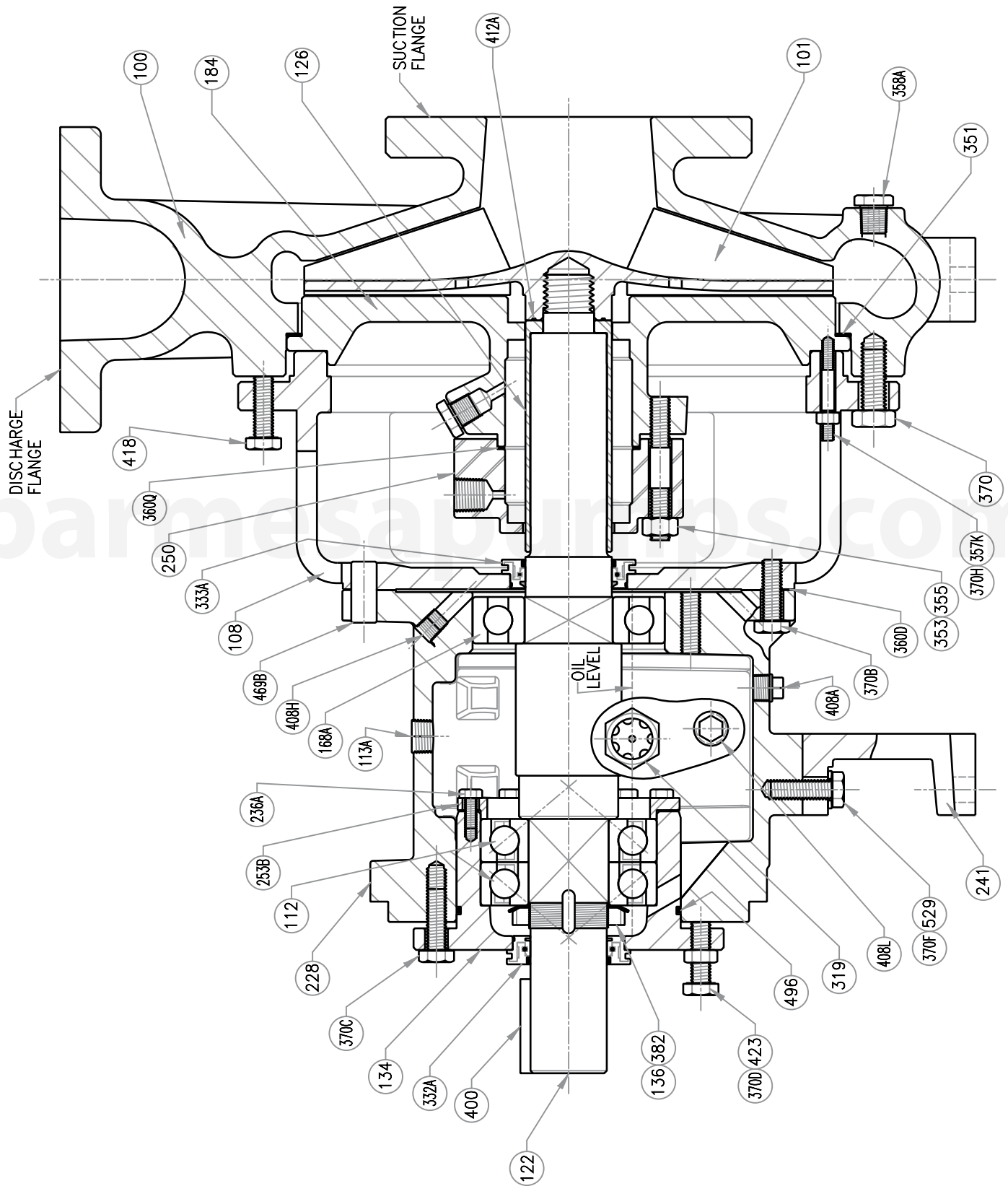

PART LIST

Series: 911L

ITEM	QTY.	DESCRIPTION	MATERIAL	PART No.
100	1	Casing 1x2-10	Cast iron	03730100
			CF8M	03730101
		Casing 1.5x3-10	Cast iron	03730110
			CF8M	03730111
		Casing 2x3-10	Cast iron	03730120
			CF8M	03730121
		Casing 3x4-10	Cast iron	03730130
			CF8M	03730131
		Casing 3x4-10H	Cast iron	03730140
			CF8M	03730141
		Casing 4x6-10	Cast iron	03730150
			CF8M	03730151
		Casing 4x6-10H	Cast iron	03730160
			CF8M	03730161
101	1	Impeller 1x2-10	Cast iron	03750100B
			CF8M	03750101B
		Impeller 1.5x3-10	Cast iron	03750110B
			CF8M	03750111B
		Impeller 2x3-10	Cast iron	03750120B
			CF8M	03750121B
		Impeller 3x4-10	Cast iron	03750130B
			CF8M	03750131B
		Impeller 3x4-10H	Cast iron	03750140B
			CF8M	03750141B
		Impeller 4x6-10	Cast iron	03750150B
			CF8M	03750151B
		Impeller 4x6-10H	Cast iron	03750160B
			CF8M	03750161B
105	1	Lantern ring 911 L	Teflon®	S/N
106	5	Cord ring 3/8"	Teflon®	S/N
107	1	Stuffing box 911 L	CF8M	S/N
108	1	Adapter 10"	Cast iron	03710003
112	1	Outer bearing	Steel	31020028
113A	1	Dry seal cap 1/2"	Steel	93010112
122	1	Shaft with sleeve	Steel 4140	30300353
		Shaft without sleeve	316 SS	30300361
126	1	Sleeve	316 SS	30300683
134	1	Bearing support	Cast iron	03780003
136	1	Safety nut M10	Steel	91010452
168A	1	Inner bearing	Steel	31020015
184	1	Seal plate 10"	Cast iron	03770060
			CF8M	03770061
228	1	Frame 911 L	Cast iron	03720003
236A	10	Screw 5/16" x 3/4"	Steel	91010221
241	1	Frame support 8 1/4"	Cast iron	03790001
		Frame support 10"	Cast iron	03790002
253B	1	Clamp ring 911 L	Steel	30400352
319	1	Oil sight glass	Steel/Glass	31120011
332A	1	Outboard lab'y seal 911 L	Bronze	31030206
333A	1	Inboard lab'y seal 911 L	Bronze	31030205
351	1	Body gasket 10"	EPDM	92010197
353	4	Stud screw 1/2"x 3/4" lgo.	304 SS	91010378
355	4	Nut 1/2"	304 SS	91010435
357K	2	Nut 5/16"	304 SS	91010432
358C	1	Plug 3/8"	Cast iron	93010149
			304 SS	93010131
360D	1	Adapter gasket	Vellumoid	92010171
360Q	1	Seal flange gasket	EPDM	92010185
370	12	Screw 5/8"x 1 1/2"	Carbon Steel	91010282
			304 SS	91010354
370B	4	Screw 1/2"x 1 1/2"	Carbon Steel	91010263
370C	3	Screw 1/2"x 1 1/2"	Carbon Steel	91010263
370D	3	Screw 1/2"x 1 1/2"	Carbon Steel	91010263
370F	2	Screw 1/2"x 1 1/2"	Carbon Steel	91010263
370H	2	Stud screw 5/16" x 2 3/4"	304 SS	91010372
382	1	Lock washer MB10	Steel	91010067

ITEM	QTY.	DESCRIPTION	MATERIAL	PART No.
400	1	Key 1/2"	Steel 1018	30400637
408A	1	Plug 3/8"	Cast iron	93010149
408H	4	Dry seal cap 1/4"	Steel	93010113
408J	1	Dry seal cap 1/4"	Steel	93010113
408L	1	Dry seal cap 1/2"	Steel	93010112
408M	1	Dry seal cap 1"	Steel	93010111
412A	1	Impeller gasket	Teflon®	92010058
418	3	Screw 1/2"x 1 1/2"	304 SS	91010351
423	3	Nut 1/2"	Steel	91010415
496	1	Support gasket	Buna-N	92010042
529	2	Spring washer	Steel	91010014

ITEM	QTY.	DESCRIPTION	MATERIAL	PART No.
100	1	Casing 1.5x3-13	Cast iron	03730170
			CF8M	03730171
		Casing 2x3-13	Cast iron	03730180
			CF8M	03730181
		Casing 3x4-13	Cast iron	03730190
			CF8M	03730191
		Casing 4x6-13	Cast iron	03730200
			CF8M	03730201
101	1	Impeller 1.5x3-13	Cast iron	03750170B
			CF8M	03750171B
		Impeller 2x3-13	Cast iron	03750180B
			CF8M	03750181B
		Impeller 3x4-13	Cast iron	03750190B
			CF8M	03750191B
		Impeller 4x6-13	Cast iron	03750200B
			CF8M	03750201B
105	1	Lantern ring 911 L	Teflon®	S/N
106	5	Cord ring 3/8"	Teflon®	S/N
107	1	Stuffing box 911 L	CF8M	S/N
108	1	Adapter 13"	Cast iron	03710004
112	1	Outer bearing	Steel	31020028
113A	1	Dry seal cap 1/2"	Steel	93010112
122	1	Shaft 911 L	Steel 4140	30300353
		Solid shaft 911 L	316 SS	30300361
126	1	Sleeve 911 L	316 SS	30300683
134	1	Bearing support	Cast iron	03780003
136	1	Safety nut M10	Steel	91010452
168A	1	Inner bearing	Steel	31020015
184	1	Seal plate 13"	Cast iron	03770070
184		Seal plate 13"	CF8M	03770071
228	1	Frame 911 L	Cast iron	03720003
236A	10	Screw 5/16" x 3/4"	Steel	91010221
241	1	Frame support 10"	Cast iron	03790002
253B	1	Clamp ring 911 L	Steel	30400352
319	1	Oil sight glass	Steel/Glass	31120011
332A	1	Outboard lab'y seal 911 L	Bronze	31030206
333A	1	Inboard lab'y seal 911 L	Bronze	31030205
351	1	Body gasket 13"	EPDM	92010198
353	4	Stud screw 1/2"x 3/4" lgo.	304 SS	91010378
355	4	Nut 1/2"	304 SS	91010435
357K	2	Nut 5/16"	304 SS	91010432
358C	1	Plug 3/8"	Cast iron	93010149
			304 SS	93010131
360D	1	Adapter gasket	Vellumoid	92010171
360Q	1	Seal flange gasket	EPDM	92010185
370	16	Screw 5/8"x 1 1/2"	Carbon Steel	91010282
			304 SS	91010354
370B	4	Screw 1/2"x 1 1/2"	Carbon Steel	91010263
370C	3	Screw 1/2"x 1 1/2"	Carbon Steel	91010263
370D	3	Screw 1/2"x 1 1/2"	Carbon Steel	91010263
370F	2	Screw 1/2"x 1 1/2"	Carbon Steel	91010263
370H	2	Stud screw 5/16" x 2 3/4"	304 SS	91010372
382	1	Lock washer MB10	Steel	91010067
400	1	Key 1/2"	Steel 1018	30400637
408A	1	Plug 3/8"	Cast iron	93010149
408H	4	Dry seal cap 1/4"	Steel	93010113
408J	1	Dry seal cap 1/4"	Steel	93010113
408L	1	Dry seal cap 1/2"	Steel	93010112
408M	1	Dry seal cap 1"	Steel	93010111
412A	1	Impeller gasket	Teflon®	92010058
418	3	Screw 1/2"x 1 1/2"	304 SS	91010351
423	3	Nut 1/2"	Steel	91010415
496	1	Support gasket	Buna-N	92010042
529	2	Spring washer	Steel	91010014

EXPLODED VIEW DRAWING

Series: 911LX

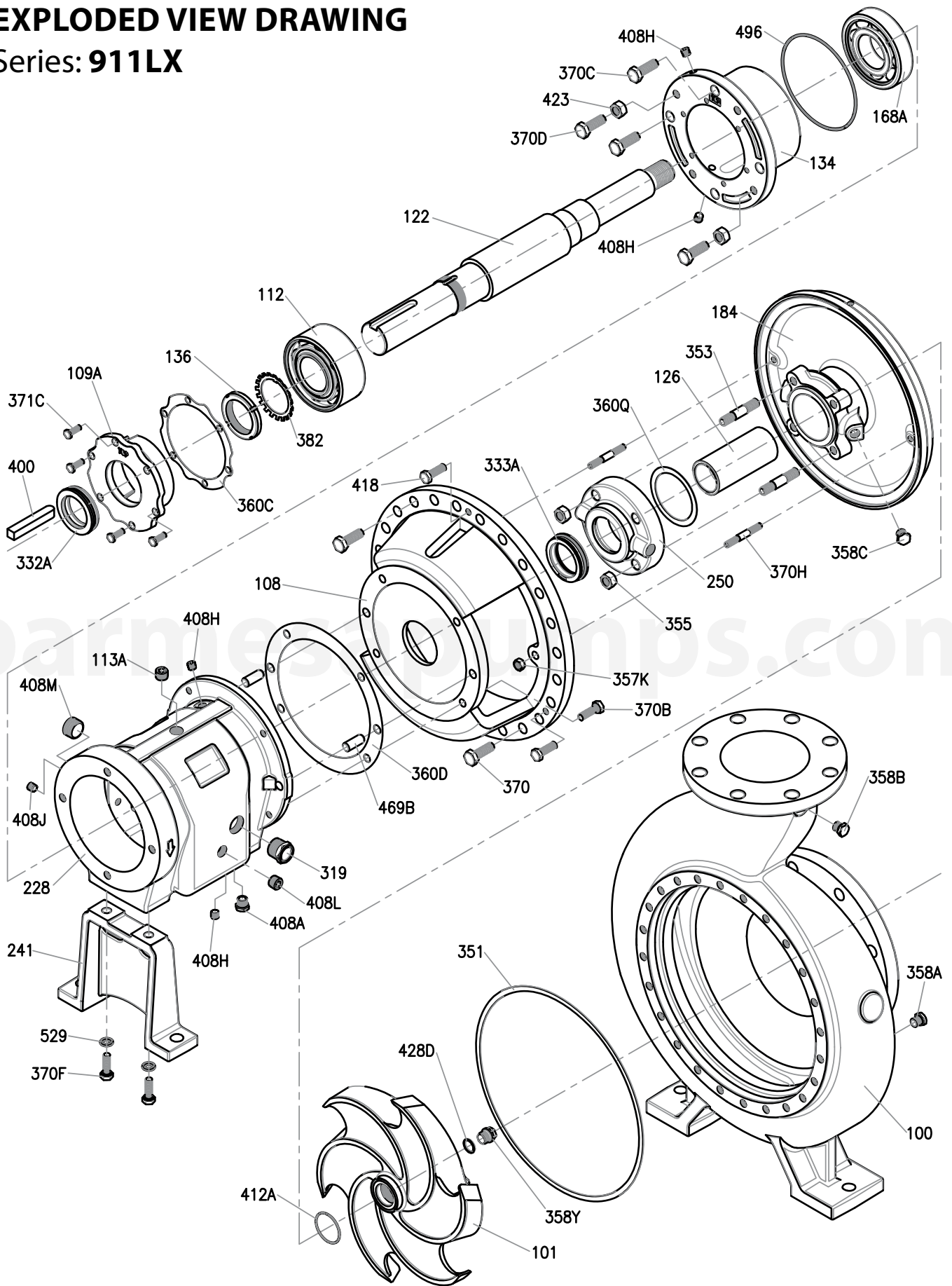

SECTIONAL VIEW DRAWING

Series: 911LX

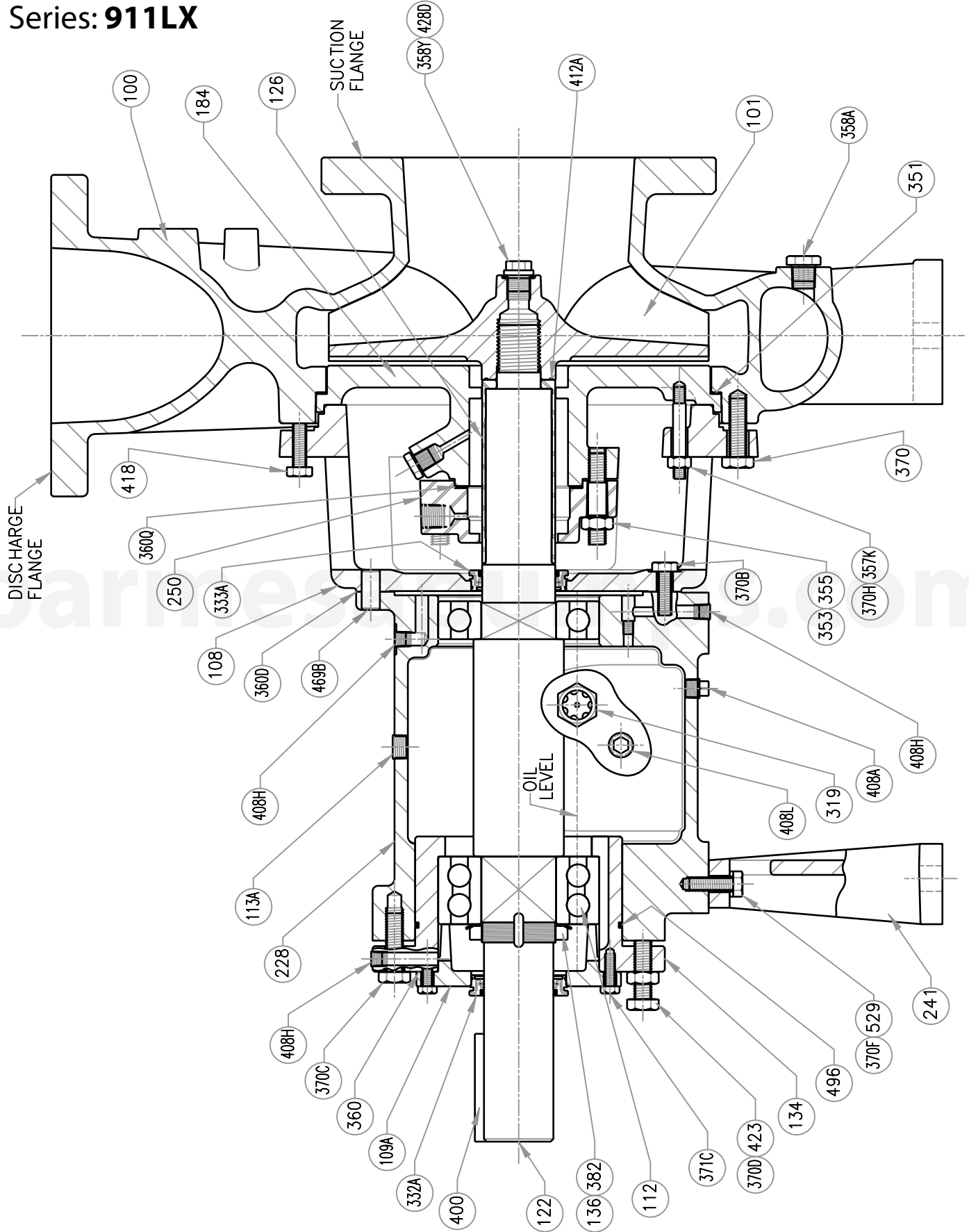

PART LIST

Series: 911LX

ITEM	QTY.	DESCRIPTION	MATERIAL	PART No.
100	1	Casing 6x8-13	Cast iron	03730210
			CF8M	03730211
		Casing 8x10-13	Cast iron	03730220
			CF8M	03730221
101	1	Impeller 6x8-13	Cast iron	03750210
			CF8M	03750211
		Impeller 8x10-13	Cast iron	03750220
			CF8M	03750221
105	1	Lantern ring 911 LX	Teflon®	S/N
106	5	cord ring 7/16"	Teflon®	S/N
107	1	Stuffing box 911 LX	CF8M	S/N
108	1	Adapter of 13", 911 LX	Cast iron	03710005
109C	1	Cover for bearing support	Cast iron	03790101
112	1	Outer bearing	Steel	31020041
113A	1	Dry seal cap ½"	Steel	93010112
122	1	Shaft with sleeve	Steel 4140	30300354
		Shaft without sleeve	316 SS	30300362
126	1	Sleeve 911 LX	316 SS	30300684
134	1	Bearing support	Cast iron	03780004
136	1	Safety nut M13	Steel	91010458
168A	1	Inner bearing	Steel	31020042
184	1	Seal plate of 13"	Cast iron	03770080
			CF8M	03770081
228	1	Frame 911 LX	Cast iron	03720004
241	1	Frame holder 14½"	Cast iron	03790003
319	1	Oil sight glass	Steel/Glass	31120011
332A	1	Outboard lab'y seal 911 LX	Bronze	31030207
333A	1	Inboard lab'y seal 911 LX	Bronze	31030208
351	1	Body gasket 13"	EPDM	92010198
353	4	Stud screw 5/8"x 3½" lgo.	304 SS	91010385
355	4	Nut 5/8"	304 SS	91010436
357K	2	Nut ½"	304 SS	91010435
358C	1	Plug 3/8"	Cast iron	93010149
			304 SS	93010131
358Y	1	Impeller nut	316 SS	30400908
360	1	Gasket stand cap	Vellumoid	92010076
360D	1	Adapter gasket	Vellumoid	92010171
360Q	1	Seal flange gasket	EPDM	92010184
370	16	Screw 5/8"x 2"	Carbon steel	91010283
			304 SS	91010356
370B	4	Screw ½"x 1½"	Carbon steel	91010263
370C	4	Screw 5/8"x 1½"	Carbon steel	91010282
370D	4	Screw 5/8"x 2"	Carbon steel	91010283
370F	2	Screw ½"x 1½"	Carbon steel	91010263
370H	2	Stud screw ½" x 3¼"	304 SS	91010378
371C	1	Screw 3/8"x 1¼"	Carbon steel	91010243
382	1	Lock washer MB13	Steel	91010068
400	1	Key 5/8"	Steel 1018	30400630
408A	1	Plug 3/8"	Cast iron	93010149
408H	4	Dry seal cap ¼"	Steel	93010113
408J	1	Dry seal cap ¼"	Steel	93010113
408L	1	Dry seal cap ½"	Steel	93010112
408M	1	Dry seal cap 1"	Steel	93010111
412A	1	Impeller gasket	Teflon®	92010073
418	3	Screw ½"x 1½"	304 SS	91010351
423	4	Nut 5/8"	Steel	91010416
428D	1	Impeller cap gasket	Teflon®	92010074
469B	2	Guide pin	Steel 1018	30400864
496	1	Support gasket	Buna-N	92010075
529	2	Spring washer	Steel	91010014

ITEM	QTY.	DESCRIPTION	MATERIAL	PART No.
100	1	Casing 6x8-15	Cast iron	03730230
			CF8M	03730231
		Casing 8x10-15	Cast iron	03730240
			CF8M	03730241
		Casing 8x10-15G	Cast iron	03730250
			CF8M	03730251
101	1	Impeller 6x8-15	Cast iron	03750230
			CF8M	03750231
		Impeller 8x10-15	Cast iron	03750240
			CF8M	03750241
		Impeller 8x10-15G	Cast iron	03750250
			CF8M	03750251
105	1	Lantern ring 911 LX	Teflon®	S/N
106	5	cord ring 7/16"	Teflon®	S/N
107	1	Stuffing box 911 LX	CF8M	S/N
108	1	Adapter of 15"	Cast iron	03710006
109C	1	Cover for bearing support	Cast iron	03790101
112	1	Outer bearing	Steel	31020041
113A	1	Dry seal cap ½"	Steel	93010112
122	1	Shaft with sleeve	Steel 4140	30300354
		Shaft without sleeve	316 SS	30300362
126	1	Sleeve 911 LX	316 SS	30300684
134	1	Bearing support	Cast iron	03780004
136	1	Safety nut M13	Steel	91010458
168A	1	Inner bearing	Steel	31020042
184	1	Seal plate of 15"	Cast iron	03770090
			CF8M	03770091
228	1	Frame 911 LX	Cast iron	03720004
241	1	Frame holder 14½"	Cast iron	03790003
319	1	Oil sight glass	Steel/Glass	31120011
332A	1	Outboard lab'y seal 911 LX	Bronze	31030207
333A	1	Inboard lab'y seal 911 LX	Bronze	31030208
351	1	Body gasket 15"	EPDM	92010204
353	4	Stud screw 5/8"x 3½" lgo.	304 SS	91010385
355	4	Nut 5/8"	304 SS	91010436
357K	2	Nut ½"	304 SS	91010435
358C	1	Plug 3/8"	Cast iron	93010149
			304 SS	93010131
358Y	1	Impeller nut	316 SS	30400908
360	1	Gasket stand cap	Vellumoid	92010076
360D	1	Adapter gasket	Vellumoid	92010171
360Q	1	Seal flange gasket	EPDM	92010184
370	24	Screw 5/8"x 2"	Carbon steel	91010283
			304 SS	91010356
370B	4	Screw ½"x 1½"	Carbon steel	91010263
370C	4	Screw 5/8"x 1½"	Carbon steel	91010282
370D	4	Screw 5/8"x 2"	Carbon steel	91010283
370F	2	Screw ½"x 1½"	Carbon steel	91010263
370H	2	Stud screw ½" x 3¼"	304 SS	91010378
371C	1	Screw 3/8"x 1¼"	Carbon steel	91010243
382	1	Lock washer MB13	Steel	91010068
400	1	Key 5/8"	Steel 1018	30400630
408A	1	Plug 3/8"	Cast iron	93010149
408H	4	Dry seal cap ¼"	Steel	93010113
408J	1	Dry seal cap ¼"	Steel	93010113
408L	1	Dry seal cap ½"	Steel	93010112
408M	1	Dry seal cap 1"	Steel	93010111
412A	1	Impeller gasket	Teflon®	92010073
418	3	Screw ½"x 1½"	304 SS	91010351
423	4	Nut 5/8"	Steel	91010416
428D	1	Impeller cap gasket	Teflon®	92010074
469B	2	Guide pin	Steel 1018	30400864
496	1	Support gasket	Buna-N	92010075
529	2	Spring washer	Steel	91010014



Risk of electric shock. Always disconnect the pump from the power source before handling inspections or repairs.

PROBLEMS THAT MAY BE PRESENT AT THE PUMP		
PROBLEM	PROBABLE CAUSE	SOLUTION
The pump does not carry nominal flow or height.	Partially clogged impeller.	Flush the pump reverse drain to clean the impeller.
	Insufficient suction lift.	Make sure the suction valve is completely open and free of foreign matter.
	Broken or worn impeller.	Inspect and replace if necessary.
	Worn suction plate.	Replace the defective part.
	Air entering through the gasket.	Replace the gasket.
	Air enter through the gland.	Replace or readjust gasket/mechanical seal.
Bearings warming.	The lubricant cooling system.	Inspect the cooling system.
	Improper alignment.	Realign the pump and motor.
	Inadequate lubrication.	Verify that the oil level is adequate.
Gland excessive leakage.	Mechanical seals overheated.	Verify lubrication and cooling lines.
	Scratches on the surface of the sleeve.	Replace the sleeve.
	The gland improperly adjusted.	Tighten bolts cap.
	Worn mechanical seal parts.	Replace worn parts.
	Gland improperly lled.	Verify gasket and re ll the gland.
Pump is not delivering liquid.	The pump is not primed.	Re-prime the pump and verify that the pump and suction line are full of liquid.
	Clogged suction line.	Remove obstructions.
	Wrong direction of rotation.	Change rotation so that it follows with the direction indicated by the shaft on the bearing box or the pump volute.
	Suction valve or suction tube not sufficiently submerged.	Consult factory for proper depth. Use a detector to eliminate vortices.
	Suction lift too high.	Shorten the suction pipe.
The engine requires excessive power.	Rotating parts touch against each other.	Verify internal wear parts checking for the proper clearance.
	Liquid heavier than expected.	Verify speci c gravity and viscosity.
	Height lower than regime. Pumping too much liquid.	Consult the factory, install throttle valve, adjust the impeller diameter.
	The bearing gland too tight.	Readjust the gasket. Replace if worn.
Pump is noisy and vibrates.	Worn bearings.	Replace barings.
	Broken or bend impeller/shaft.	Replace as needed.
	No rigid foundation	Tighten the anchors securing the pump and motor or adjust the brackets.
	The pump is cavitating	System problem.
	Improper alignment of the pump/motor.	Align the shafts.
	Partially clogged impeller causing imbalance.	Flush the pump drain reverse to clean the impeller.
	Suction or discharge piping is not anchored or properly supported.	Anchor according to recommendations and standards.
The pump starts and after a while it stops pumping.	Air entering the suction line.	Repair leak.
	Air pockets or vapor in suction line.	Arrange piping to eliminate air pockets.
	Pump primed inappropriately.	Re-prime the pump.

NOTE: Barmesa Pumps assumes no responsibility for damage or injury due to disassembly in the field. Disassembly of the pumps or supplied accessories other than at Barmesa Pumps or its authorized service centers, automatically voids warranty.

BARMESA PUMPS FACTORY WARRANTY

Barmesa Pumps warrants that products of our manufacture will be free of defects in material and workmanship under normal use and service for 18 months from date of manufacture or 12 months from installation date whichever occurs first. This warranty gives you specific legal rights, which vary from state to state.

This warranty is a limited warranty, and no warranty related claims of any nature whatsoever shall be made against Barmesa Pumps, until the ultimate consumer or his/her successor notifies us in writing of the defect and delivers the product and/or defective part(s) freight prepaid to our factory or nearest authorized service station as instructed by Barmesa Pumps. THERE SHALL BE NO FURTHER LIABILITY, WHETHER BASED ON WARRANTY, NEGLIGENCE OR OTHERWISE. PRODUCT SHALL BE EITHER REPLACED OR REPAIRED AT THE ELECTION OF BARMESA PUMPS. Guarantees relating to performance specifications provided in addition to the foregoing material and workmanship warranties on a product manufactured by Barmesa Pumps, if any, are subject to possible factory testing. Any additional guarantees, in the nature of certified performance specifications or time frame must be in writing and such writing must be signed by our authorized factory manager at time of order placement and/or at time of quotation. Due to inaccuracies in field testing and should a conflict arises between the results of field testing conducted by or for the user, Barmesa Pumps reserves the right to have the product returned to our factory for additional testing.

This warranty shall not apply when damage is caused by (1) improper installation, (2) improper voltage, (3) lightning, (4) excessive sand or other abrasive material, (5) corrosion build-up due to excessive chemical content or (6) uncontrollable acts of god. Any modification of the original equipment will also void the warranty. We will not be responsible for loss, damage or labor cost due to interruption of service caused by defective pumps, parts or systems. Barmesa Pumps will not accept charges incurred by others without our prior written approval.

This warranty is void if our inspection reveals the product was used in a manner inconsistent with normal industry practice and/or our specific recommendations. The purchaser is responsible for communication of all necessary information regarding the application and use of the product. UNDER NO CIRCUMSTANCES WILL WE BE RESPONSIBLE FOR ANY OTHER DIRECT OR CONSEQUENTIAL DAMAGES, INCLUDING BUT NOT LIMITED TO TRAVEL EXPENSES, CONTRACTOR FEES, UNAUTHORIZED REPAIR SHOP EXPENSES, LOST PROFITS, LOST INCOME, LABOR CHARGES, DELAYS IN PRODUCTION, IDLE PRODUCTION, WHICH DAMAGES ARE CAUSED BY ANY DEFECTS IN MATERIAL AND/OR WORKMANSHIP AND/OR DAMAGE OR DELAYS IN SHIPMENT. THIS WARRANTY IS EXPRESSLY IN LIEU OF ANY OTHER EXPRESS OR IMPLIED WARRANTY. No rights extended under this warranty shall be assigned to any other person, whether by operation of law or otherwise, without our prior written approval.

IMPORTANT!

If you have a claim under the provision of the warranty, contact Barmesa Pumps or your authorized Barmesa Pumps Distributor:
warranty@barmesapumps.com
www.barmesapumps.com

