

BES2020HCU

2" x 2"

Universal Drive



IMPORTANT! - Read all instructions in this manual before operating or servicing a pump.

Before installation, read the following instructions carefully. Failure to follow instruction and safety information could cause serious bodily injury, death and/or property damage. Each Barmesa product is carefully inspected to insure proper performance. Closely following these instructions will eliminate potential operating problems, assuring years of trouble-free service.

⚠ DANGER Indicates an imminently hazardous situation which, if not avoided, WILL result in death or serious injury.

⚠ WARNING Indicates an imminently hazardous situation which, if not avoided, MAY result in death or serious injury.

⚠ CAUTION Indicates a potentially hazardous situation which, if not avoided, MAY result in minor or moderate injury.

IMPORTANT! - Barmesa Pumps is not responsible for losses, injury or death resulting from failure to observe these safety precautions, misuse, abuse or misapplication of pumps or equipment.

⚠ ALL RETURNED PRODUCTS MUST BE CLEANED, SANITIZED, OR DECONTAMINATED PRIOR TO SHIPMENT, TO INSURE EMPLOYEES WILL NOT BE EXPOSED TO HEALTH HAZARDS IN HANDLING SAID MATERIAL. ALL APPLICABLE LAWS AND REGULATIONS SHALL APPLY.

⚠ WARNING Installation, wiring, and junction connections must be in accordance with the National Electric Code and all applicable state and local codes. Requirements may vary depending on usage and location.

⚠ WARNING Installation and servicing is to be conducted by qualified personnel only.

 Keep clear of suction and discharge openings. Do not insert fingers in pump with power connected; the impeller can cause serious injury.

 Always wear eye protection when working on pumps. Do not wear loose clothing that may become entangled in moving parts.

⚠ DANGER Pumps build up heat and pressure during operation. Allow time for pumps to cool before handling or servicing the pump or any accessory items associated with or near the pump. Do not block or restrict the discharge pipe/hose.

⚠ DANGER Operation against a closed discharge valve will cause premature bearing and seal failure. Heat build up on end-suction pumps may cause dangerous pressures. A high temperature switch or pressure relief valve is recommended to be installed in pump case.

⚠ WARNING Do not pump hazardous materials (flammable, caustic, etc.) or use these pumps in water over 180 °F. Do not exceed manufacturers recommended maximum performance, as this could cause the motor to overheat.

⚠ DANGER Risk of electric shock. To reduce risk of electric shock, always disconnect pump from power source before handling any aspect of the pumping system. **Lock out power and tag.**

⚠ DANGER Failure to permanently ground the pump, motor and controls before connecting to power can cause shock, burns or death.

⚠ DANGER This pump is not intended for use in swimming pools or water installations where there is human contact with pumped fluid.

⚠ WARNING Carefully read instruction manuals supplied with motor or engine before operating or servicing.

⚠ WARNING If engine driven, never operate in an enclosed building or area where exhaust gases can accumulate, or near a building where gases can seep inside; always take provisions for adequate ventilation.

⚠ WARNING Pumps constructed with or fitted with bronze/brass may contain lead levels higher than considered safe for potable water systems. Lead is known to cause cancer and birth defects or other reproductive harm. Various government agencies have determined that leaded copper alloys should not be used in potable water applications.

IMPORTANT! - Prior to installation, record model and serial number from pump name plate for the future reference. Also record the Voltage and Current Readings at Startup:

Model Number: _____

Serial: _____

SUCTION:	2" NPT horizontal.
DISCHARGE:	2" 125 lb. ANSI. It can be placed in 8 different locations depending on piping requirements.
LIQUID TEMPERATURE:	180 °F (82 °C) continuous.
BODY:	Cast iron ASTM A-48, class 30 with air vent, vacuum pressure and drain plugs.
PEDESTAL:	Cast iron ASTM A-48.
IMPELLER:	Enclosed type, dynamically balanced, ISO G6.3.
SHAFT:	Steel.
SHAFT SLEEVE:	Bronze.
HARDWARE:	Steel.
WEARING:	Teflon "U" cup.
PAINT:	Air dry enamel, water based.
MECHANICAL SEAL:	Single, water lubrication. Material: carbon / Ni-Resist / Buna-N.
BEARING-DRIVE END:	Double row, ball, pre-greased at factory load-radial & thrust.
BEARING-PUMP END:	Single row, ball, pre-greased at factory load-radial & thrust.
WEIGHT:	74 lb. (33.6 kg).

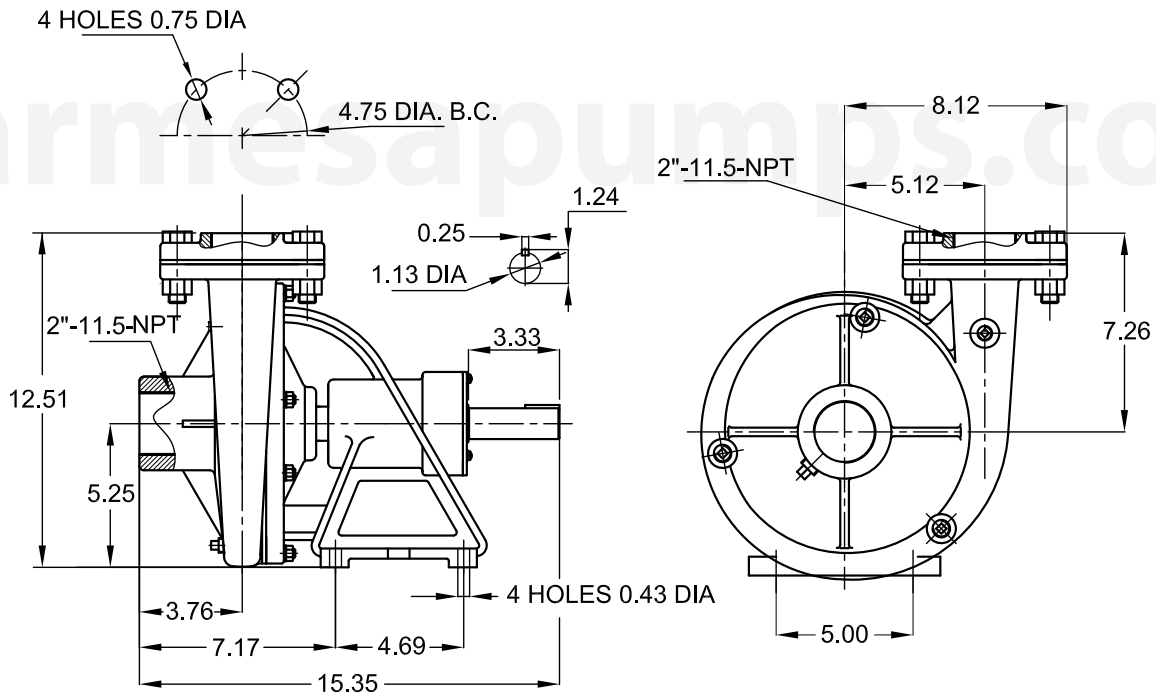

► Receiving inspection

Upon receiving the pump, it should be inspected for damage or shortages. If damage has occurred, file a claim immediately with the company that delivered the pump. If the manual is removed from the packaging, do not lose or misplace.

► Storage

Any product that is stored for a period longer than six (6) months from the date of purchase should be bench tested prior to installation. A bench test consists of, checking the impeller to assure it is free turning and a run test to assure the motor (and switch if provided) operate properly. Do not pump out of liquid.

► Location

Locate pump as near as possible to the liquid being pumped.

Do not place pump more than 15 feet above the surface of the liquid supply. Be sure pump is level. Mount pump firmly so not to move due to vibration.

Units should be permanently grouted onto a cement foundation. The pumps should be level to provide correct operating conditions. The flexible coupling should be realigned after grouting to eliminate excessive wear on the coupling.

► Controls

Be sure the electrical specification of the control selected properly match the electrical specifications of the motor.

► Motor connection

All wiring of motor and control, overload protection and grounding should be in accordance with the National Electrical Code, State and Local codes. Make motor connection per label located on motor or motor manufacturer's manual.

► Rotation

Pump rotation should agree with the direction on the rotation plate. If rotation on 3 phase is incorrect, interchange any two incoming wire leads. Rotation is "clockwise" when looking from the motor end.

The impeller is threaded on the shaft and it is necessary to slide one half of the coupling back when checking rotation in order to eliminate the possibility of unscrewing the impeller and damaging the pump.

► Suction

⚠ CAUTION Pump should not be operated without a suction strainer to prevent foreign matter from being drawn into impeller. The strainer should be cleaned regularly.

The use of pipe the same size as the port size is highly recommended. Using a smaller pipe line can cause internal damage. Make sure all lines have air-tight joints. The smallest air leak in the suction line may prevent the pump from priming.

All horizontal suction lines should slope up to the pump to avoid trapped air pockets. If hose is used, it should be of reinforced type to prevent collapsing under suction.

► Discharge

Connect discharge hose or pipe to the discharge port. Make sure all lines are air-tight joints.

► Driver

Refer to engine or motor manufacturer's instructions.

► Lubrication

The shaft seal and impeller are lubricated by the liquid being pumped and needs no other lubrication. The bearings have been factory packed with lubricant and should be good for 5,000 hours or one year, then repacked.

► Priming

Prime pump by completely filling volute and suction line with liquid. Allow air to escape by loosening pipe plug (4) in top of volute (1).

Make sure all the air is out of the suction line and volute, or pump will not prime properly. A foot valve is required for priming or flooded suction. In freezing weather prime pump with warm water.



IMPORTANT! - Do not operate pump without priming first. Operating dry will damage seal.

► Starting

To start pump, apply power to motor or engine per its manufacturer's instructions.

► Shutdown

Disconnect electric power or stopping engine to shut down. It is recommended to drain and flush pump if pump has been operating in freezing weather.

► Service

Turn off and lock out power before servicing pump.

► Impeller

Remove hex nuts (8) and lockwashers (7) then remove volute (1) and o-ring (5) from bearing pedestal (13). If impeller (2) needs replacement, unscrew from shaft. The impeller has right hand threads, so to break loose use a block of wood against a vane and strike with hammer.

Examine u-cup (3), o-ring (5) and replace if required.

To reassemble, handle impeller carefully as not to damage the machined sealing surface of the inlet hub. This surface, if damaged will destroy the u-cup. Be sure spring of shaft seal (9) is in place before reassembling the impeller.

► Shaft seal

Remove seal's (9) spring, and rotating member from shaft sleeve (11). If any seal part shows wear or damage replace entire seal assembly.

If stationary member needs replaced, press stationary out of pedestal (13).



IMPORTANT! - Handle all seal parts with care. Do not damage lapped faces.

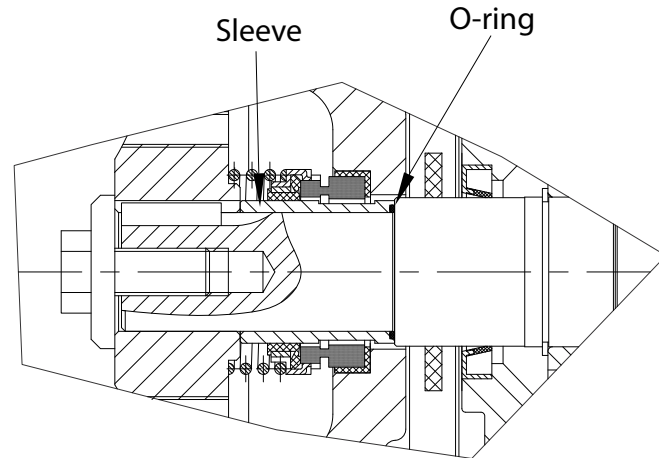

To reassemble, lightly oil and replace shaft sleeve (11), o-ring (31) and stationary member of seal (9). Press stationary member over shaft sleeve and into pedestal (13). Lightly oil inner surface of rotating member's bellows and with lapped surface facing pedestal, slide rotating member onto shaft sleeve (11) until lapped faces of stationary and rotating member are together. Make certain driving lugs in retainer are mated in carbon washer. Place spring on shaft sleeve and place on rotating member making sure it is seated on metal retainer and not cocked or resting on bellows tail.

► Shaft and bearing

Remove capscrews (16), lockwashers (15) and pull bearing cap (14) from pedestal (13). Tap on drive end of shaft with block of wood and a hammer to drive the shaft and bearings from pedestal. Press bearings (12) and (17) from shaft (19) if they need to be replaced. If bearings need to be repacked, use a lithium grease such as B.P. ENERGREASE LS2 or equal.

► Reassembly

Reassemble pump in reverse order.

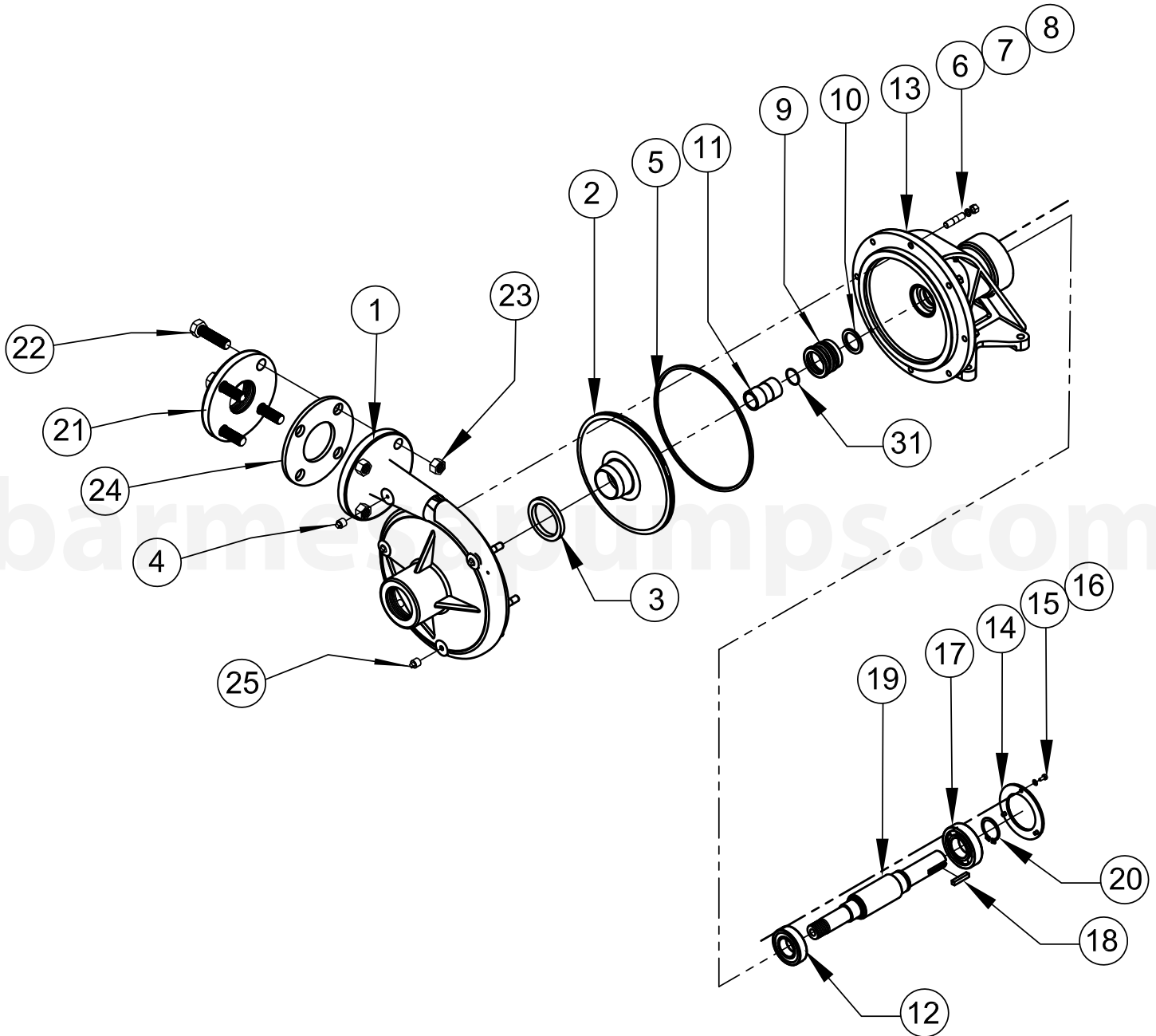

For repair part please supply: Model Number and Serial as shown on Name Plate, and Part Description and Part Number as shown on Parts List.

ITEM	QTY	DESCRIPTION
1	1	Volute
2	1	Impeller, Ø8.2", bronze
3	1	U-cup
4	2	Pipe plug, 0.25" NPT
5	1	Square ring
6	8	Stud, 5/16"-18 x 1.75"
7	8	Lockwasher, 5/16"
8	8	Hex nut, 5/16"-18
9	1	Shaft seal, C/NR/B
10	1	Slinger
11	1	Shaft sleeve
12	1	Bearing, inner - 6206ZZ
13	1	Pedestal
14	1	Bearing cap
15	3	Lockwasher, #10
16	3	Machine screw, #10-32 x 0.50"
17	1	Bearing, outer - 6207ZZ
18	1	Shaft key
19	1	Shaft
20	1	Retaining ring
21	1	Suction flange
22	4	Stud
23	4	Hex nut
24	1	Gasket
25	3	Pipe plug, 0.375" NPT
26	1	O-ring - Shaft sleeve - 25.4 mm x 1.8 mm
27	1	Seal plate
28	2	Hex hd screw, 5/16"-18 x 0.50"
29	1	Impeller Washer
30	1	Hex hd screw, 1/2"-13 x 1.25"
31	1	O-ring - Shaft Sleeve - 31.5 mm x 1.8 mm

For repair part please supply: Model Number and Serial as shown on Name Plate, and Part Description and Part Number as shown on Parts List.



Risk of electric shock. Always disconnect the pump from the power source before handling inspections or repairs.

Symptom	Possible Cause(s)	Corrective Action
Little or no discharge and will not prime.	<ol style="list-style-type: none"> 1. Pump body not filled with water. 2. Total head too high. 3. Suction head higher than pump designed for. 4. Impeller partially or completely plugged. 5. Leak in suction line. 6. Foot-valve too small. 7. Impeller damaged. 8. Foot-valve or suction line not submerged deep enough in water, pulling air. 9. Insufficient inlet pressure or suction head. 10. Suction piping too small. 11. Body gasket leaking. 12. Suction or discharge line valves closed. 13. Piping damaged. 14. Clogged strainer or foot-valve. 15. Incorrect engine speed. 	<ol style="list-style-type: none"> 1. Fill pump body with water. 2. Shorten suction head. 3. Lower suction head, install foot-valve and prime. 4. Disassemble pump and clean out impeller. 5. Repair or replace suction line. 6. Match foot-valve size to piping or install one larger size foot-valve. 7. Disassemble pump and replace impeller. 8. Submerge lower in water. 9. Increase inlet pressure by adding more water to tank or increasing back pressure by turning gate valve on discharge line partially closed. 10. Increase pipe size to pump inlet size or larger. 11. Replace. 12. Open. 13. Clean or replace. 14. Clean or replace. 15. Increase speed.
Loss of suction after satisfactory operation.	<ol style="list-style-type: none"> 1. Air leak in suction line. 2. When pump was last turned off, water siphoned out of pump body. 3. Suction head higher than pump designed for. 4. Insufficient inlet pressure or suction head. 5. Clogged foot-valve, strainer or pump. 6. Defective wear plate. 	<ol style="list-style-type: none"> 1. Repair or replace suction line. 2. Refill (reprime) pump body before restarting. 3. Lower suction head, install foot-valve and prime. 4. Increase inlet pressure by adding more water to tank or increasing back pressure by turning gate valve on discharge line to partially closed. 5. Unclog or replace. 6. Replace.
Pump overloads driver.	<ol style="list-style-type: none"> 1. Total head lower than pump rating, unit delivering too much water. 2. Specific gravity and viscosity of liquid being pumped different than the pump rating. 3. Speed too high. 	<ol style="list-style-type: none"> 1. Increase back pressure by turning gate valve on discharge line to partially closed position that will not overload motor. 2. Consult factory. 3. Check and correct speed.
Pump vibrates and/or makes excessive noise.	<ol style="list-style-type: none"> 1. Mounting plate or foundation not rigid enough. 2. Foreign material in pump causing unbalance. 3. Impeller bent. 4. Cavitation present. 5. Piping not supported to relieve any strain on pump assembly. 	<ol style="list-style-type: none"> 1. Reinforce. 2. Disassemble pump and remove. 3. Replace impeller. 4. Check suction line for proper size and check valve in suction line if completely open, remove any sharp bends before pump and shorten suction line. 5. Make necessary adjustments.
Pump runs but no fluid.	<ol style="list-style-type: none"> 1. Air leak in suction piping. 2. Pump located too far from fluid source. 3. Gate valve closed. 4. Clogged strainer. 5. Fouled foot-valve. 6. Discharge height too great. 7. Fouled impeller. 8. Faulty mechanical seal. 	<ol style="list-style-type: none"> 1. Replace. 2. Replace. 3. Open. 4. Clean or replace. 5. Clean or replace. 6. Lower the height. 7. Clean or replace. 8. Replace.
Pump leaks at shaft.	<ol style="list-style-type: none"> 1. Worn mechanical seal. 2. Seal not installed properly. 	<ol style="list-style-type: none"> 1. Replace. 2. Follow service instructions for installing seal.

NOTE: Barmesa Pumps assumes no responsibility for damage or injury due to disassembly in the field. Disassembly of the pumps or supplied accessories other than at Barmesa Pumps or its authorized service centers, automatically voids warranty.

BARMESA PUMPS FACTORY WARRANTY

Barmesa Pumps warrants that products of our manufacture will be free of defects in material and workmanship under normal use and service for 18 months from date of manufacture or 12 months from installation date whichever occurs first. This warranty gives you specific legal rights, which vary from state to state.

This warranty is a limited warranty, and no warranty related claims of any nature whatsoever shall be made against Barmesa Pumps, until the ultimate consumer or his/her successor notifies us in writing of the defect and delivers the product and/or defective part(s) freight prepaid to our factory or nearest authorized service station as instructed by Barmesa Pumps. THERE SHALL BE NO FURTHER LIABILITY, WHETHER BASED ON WARRANTY, NEGLIGENCE OR OTHERWISE. PRODUCT SHALL BE EITHER REPLACED OR REPAIRED AT THE ELECTION OF BARMESA PUMPS. Guarantees relating to performance specifications provided in addition to the foregoing material and workmanship warranties on a product manufactured by Barmesa Pumps, if any, are subject to possible factory testing. Any additional guarantees, in the nature of certified performance specifications or time frame must be in writing and such writing must be signed by our authorized factory manager at time of order placement and/or at time of quotation. Due to inaccuracies in field testing and should a conflict arises between the results of field testing conducted by or for the user, Barmesa Pumps reserves the right to have the product returned to our factory for additional testing.

This warranty shall not apply when damage is caused by (1) improper installation, (2) improper voltage, (3) lightning, (4) excessive sand or other abrasive material, (5) corrosion build-up due to excessive chemical content or (6) uncontrollable acts of god. Any modification of the original equipment will also void the warranty. We will not be responsible for loss, damage or labor cost due to interruption of service caused by defective pumps, parts or systems. Barmesa Pumps will not accept charges incurred by others without our prior written approval.

This warranty is void if our inspection reveals the product was used in a manner inconsistent with normal industry practice and/or our specific recommendations. The purchaser is responsible for communication of all necessary information regarding the application and use of the product. UNDER NO CIRCUMSTANCES WILL WE BE RESPONSIBLE FOR ANY OTHER DIRECT OR CONSEQUENTIAL DAMAGES, INCLUDING BUT NOT LIMITED TO TRAVEL EXPENSES, CONTRACTOR FEES, UNAUTHORIZED REPAIR SHOP EXPENSES, LOST PROFITS, LOST INCOME, LABOR CHARGES, DELAYS IN PRODUCTION, IDLE PRODUCTION, WHICH DAMAGES ARE CAUSED BY ANY DEFECTS IN MATERIAL AND/OR WORKMANSHIP AND/OR DAMAGE OR DELAYS IN SHIPMENT. THIS WARRANTY IS EXPRESSLY IN LIEU OF ANY OTHER EXPRESS OR IMPLIED WARRANTY. No rights extended under this warranty shall be assigned to any other person, whether by operation of law or otherwise, without our prior written approval.

IMPORTANT!

If you have a claim under the provision of the warranty, contact Barmesa Pumps or your authorized Barmesa Pumps Distributor:
warranty@barmesapumps.com
www.barmesapumps.com



